

Thread Whirling Unit

High Productive Thread Whirling with patented quick change system for significant reduction of tool set-up time.

Suitable insert holders available from leading cutting tool manufacturers.



High Productive Thread Whirling

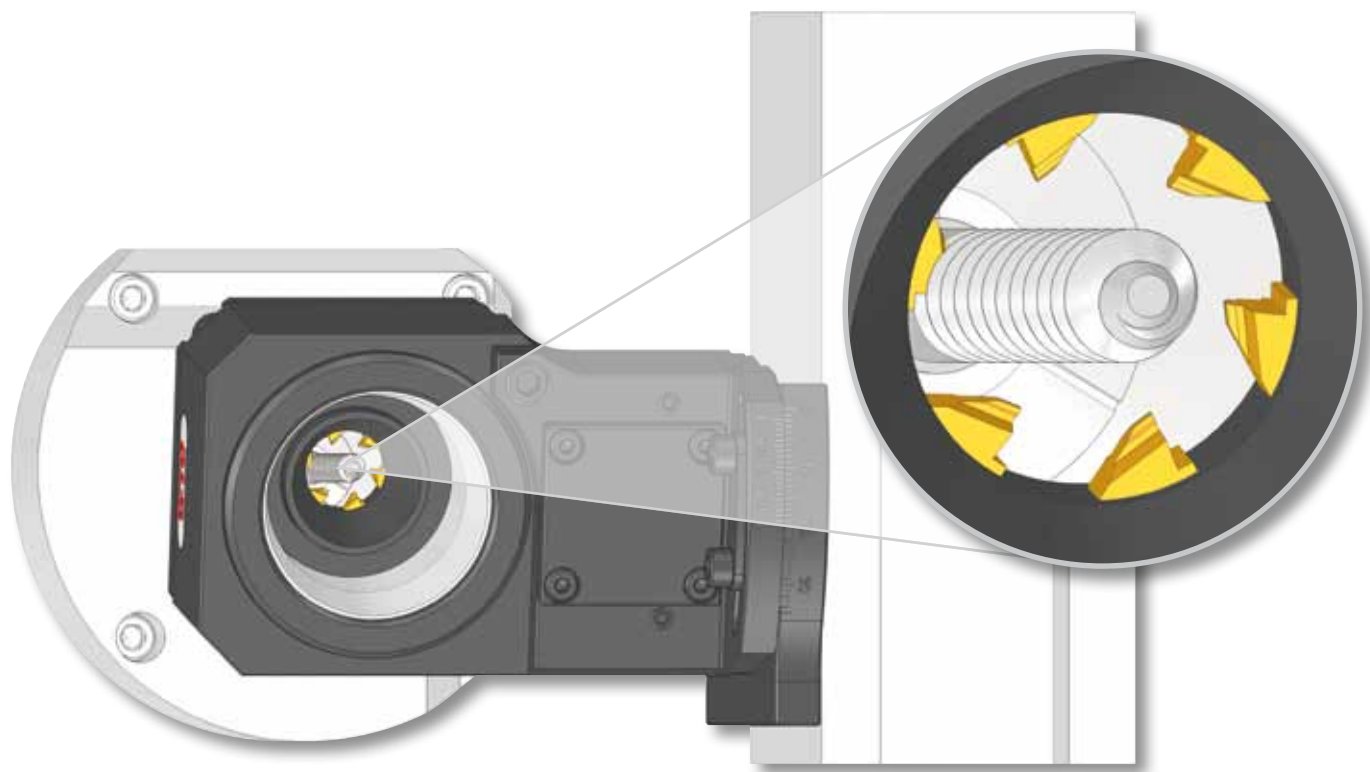

- | Patented quick change system for significant reduction of tool change time
- | The insert holder can quickly be changed from the backside
- | The thread whirling unit can remain installed and aligned in the machine tool
- | Low runout tolerance and high repeatability of the cutting inserts (± 0.005 mm)

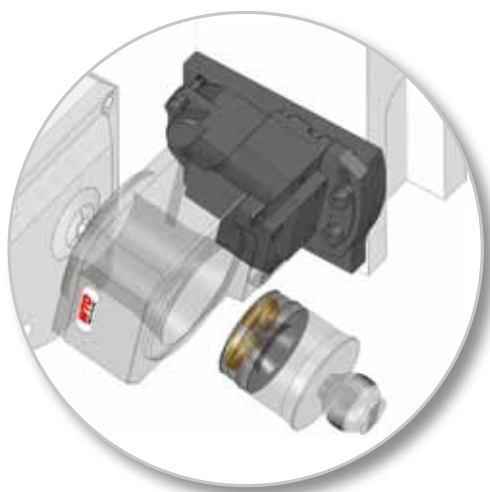
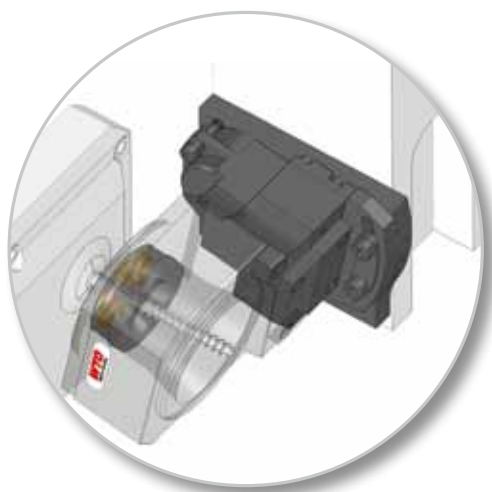

Thread whirling unit type 42BJ

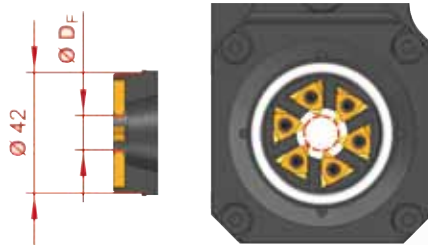

Thread whirling unit type 54BJ

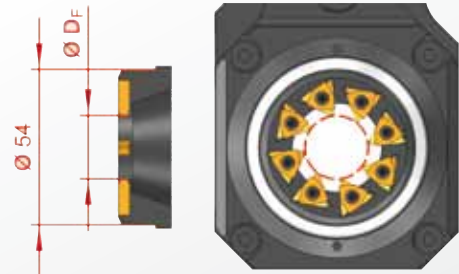

Type 42BJ		Type 54BJ
12 mm	Max. working diameter D_F	22 mm
0 – 20°	Adjustable range α	0 – 30°
4 mm	Max. profile depth t	6 mm
1 : 1	Ratio i (n1:n2)	1.36 : 1
8,000 1/min	Max. RPM (n2)	6,000 1/min

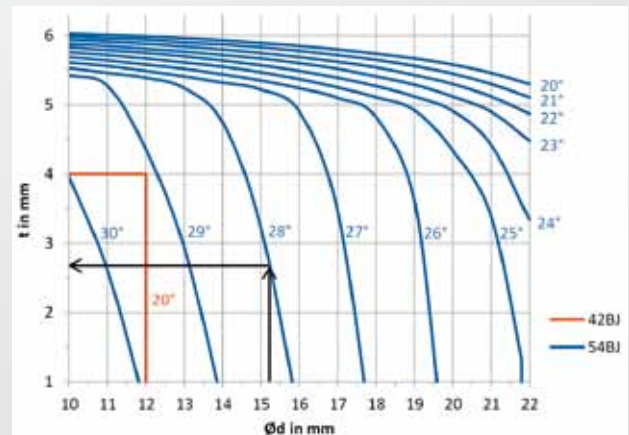
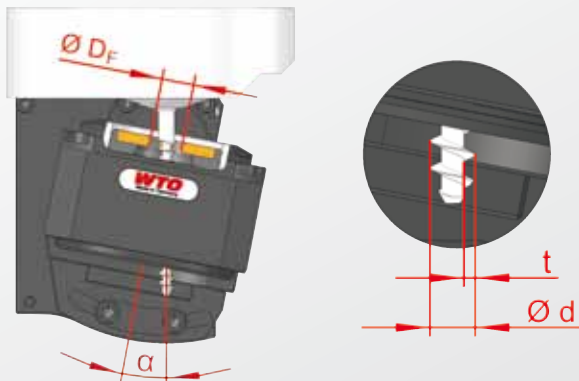

Example type 54BJ: $\varnothing d = 15.2$ mm; $\alpha = 28^\circ \rightarrow t \le 2.7$ mm

Optional accessories

Sine bar for high accurate angular adjustment

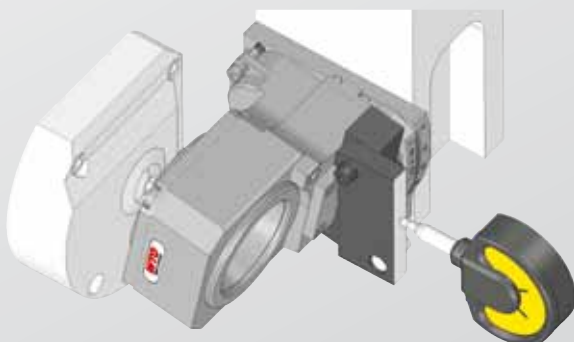

Item No. 96394

External coolant supply

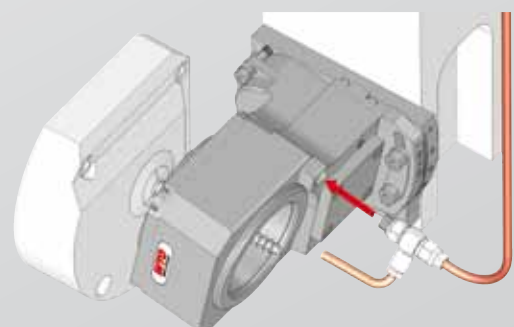

Item No. 91749

WTO worldwide

WTO
Higher Productivity

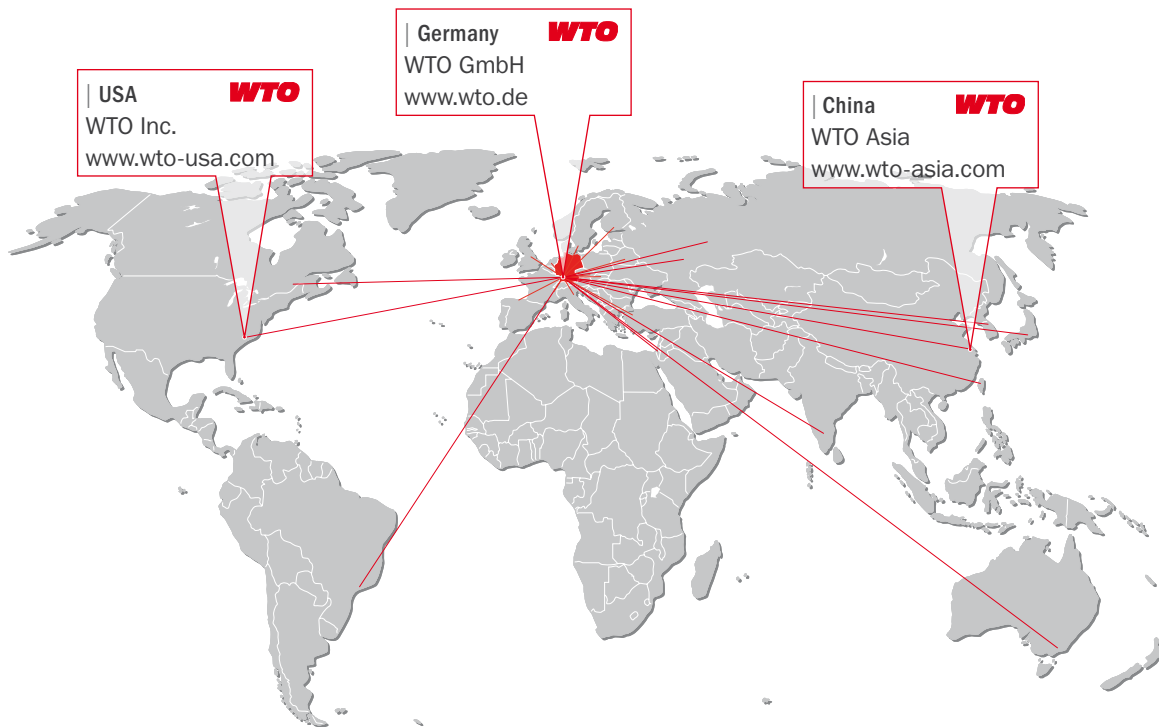

WTO GmbH
Auf der oberen Au 45
77797 Ohlsbach
Germany

WTO USA
13900 S Lakes Dr Ste F
Charlotte NC 28273-7119
USA

WTO Asia
Unit 756A, Tower 3
German Center
No. 88 Keyuan Road
Pudong
201203 Shanghai
China

Our distribution partners. Competence right there.

| **Australia**
Dimac Tooling Ltd.
sales@dimac.com.au

| **Finland**
Suomen Terästuonti Oy
myynti@stt.as

| **Japan**
NK Works Co. Ltd.
k_samba@nk-works.co.jp

| **Spain**
ITALMATIC, S.A.
italmatic@italmatic.es

| **Belarus**
JSC "PMI GROUP"
tool@pmi.by

| **France**
Société Jung
info@r-jung.com

| **Korea**
WTO Korea Office
is.chon@wto-korea.com

| **Sweden**
Komet Scandinavia AB
scandinavia@kometgroup.com

| **Brazil**
TF2
tfdois@tfdois.com.br

| **France**
Utilis France Sàrl
contact@utilis.com

| **Netherlands**
Klein Tooling B.V.
mail@kleintooling.nl

| **Switzerland**
Utilis AG
info@utilis.com

| **Canada**
Mittmann Industrial Inc.
info@mittmann.com

| **Great Britain**
Cutwel Ltd.
sales@cutwel.net

| **Norway**
Helge Karlsen Verktøy og Maskin AS
hkvm@hkvm.no

| **Taiwan**
KAIKO Enterprise Co. Ltd.
info@kaiko.com.tw

| **China**
Shanghai Gangde
m.wang@wto-asia.com

| **India**
A.H. Rao
ahr.rao@gmail.com

| **Russia**
SunTools Ltd.
info@suntools.ru

| **Turkey**
MYK CNC MAKINA SAN. VE
mehmet.karaman@mykcnc.com.tr

| **Czech Republic**
ALBA precision, spol. s.r.o.
info@albaprecision.cz

| **Israel**
E.Y.A.R. Ltd.
yehoshua@eyar.co.il

| **Slovakia**
ALBA precision s.r.o.
albaprecision@albaprecision.sk

| **Ukraine**
„LLC“ SPA Stankopromimport
info@phoenix-ua.com

| **Denmark**
Tool-part
cj@tool-part.dk

| **Italy**
Prymark srl
commerciale@prymark.it