

Kunststoff

Bearbeitungswerkzeuge

Plastic Machining

Traitement plastique



+7 812 335 59 35
info@suntools.ru



www.dieterle-tools.com



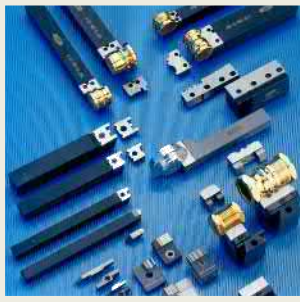

Ihr kompetenter Partner für
Werkzeugtechnik



Sehr geehrter Kunde!

Dieser "Infopunkt" soll es Ihnen erleichtern, sich in unserem Katalog zurechtzufinden.

Er verweist Sie jeweils auf die Seiten, auf denen Sie weiterführende technische Informationen und Erklärungen finden.

Dear user!

This "Infopoint" has been created to make it easier for you to find your way through our catalogue. It refers you to those pages on which you will find further technical information and explanations.

Cher utilisateur!

Ce "Point Info" est une aide pour trouver son chemin dans notre catalogue.

Il vous renvoie aux pages sur lesquelles vous trouvez des explications et des informations techniques supplémentaires.



So erreichen Sie uns:

This is how you can contact us:

Entrer en contact avec nous:

OTTO DIETERLE Spezialwerkzeuge GmbH

Predigerstrasse 56
D-78628 Rottweil

Postfach 1237
D-78612 Rottweil

Tel.: +49/741/94205-0

Fax.: +49/741/94205-50

website: www.dieterle-tools.com

e-mail: info@dieterle-tools.com

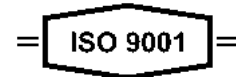

Stand/Version 07/2012

Die Angaben in diesem Katalog und der dazugehörigen Preisliste entsprechen dem Stand zu Druckbeginn. Eventuelle Änderungen oder Druckfehler berechtigen nicht zu Ansprüchen.

Mit Erscheinen dieses Kataloges werden alle entsprechenden vorherigen Kataloge ungültig.

Nachdruck von Text und Bildern, auch auszugsweise, ist ohne unsere Genehmigung nicht gestattet.

All details in this catalogue and the corresponding price list are in accordance with our current standards at the time of printing. Any modifications, changes or misprints do not entitle to damages or claims.

With the publication of this catalogue any other existing catalogue is void.

No text, photograph and drawing, even in the form of extracts, may be reprinted without our permission.

Les indications de ce catalogue correspondent à la situation actuelle. Les modifications intervenues ou éventuelles erreurs d'impression n'ouvrent pas droit à des prétentions quelqu'elles soient.

Toutes les autres catalogues sont rendues caduques par la parution de celui-ci.

La reproduction de textes et d'images, même partielle, est interdite sans notre autorisation.

Aussenbearbeitung - External machining - Usinage extérieur

System =KBS-2-7=

System =KBS-2-9=

Seiten Pages: 5 - 6

Abstechen - Cutting off - Tronçonnage

KP-2-7..S1.. **ohne Spanleitstufe**
KP-2-9..S1.. **without chip breaker**
 sans brise-copeau

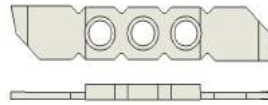

Seiten Pages: 7 - 8

Abstechen - Cutting off - Tronçonnage

KP-2-7..S1-SP.. **mit Spanleitstufe**
KP-2-9..S1-SP.. **with chip breaker**
 avec brise-copeau

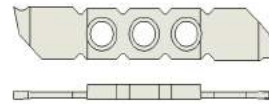

Seiten Pages: 9 - 10

Abstechen - Cutting off - Tronçonnage

KP-2-7..45°.. **Anschliff verhindert Butzen**
KP-2-9..45°.. **Special grinding eliminates pip**
 Affilage évite picot

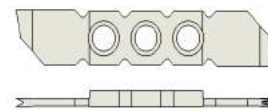

Seiten Pages: 11 - 14

Abstechen - Cutting off - Tronçonnage

KP-2-7..R3.. **Abschneiden von flexiblen Kunststoffen**
KP-2-9..R3.. **Cut off from flexible plastics**
 Trancher des plastiques flexibles

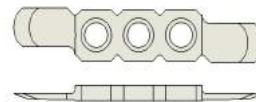

Seiten Pages: 15 - 16

Abstechen - Cutting off - Tronçonnage

KP-2-7..RX.. **Abschneiden von flexiblen Kunststoffen**
KP-2-9..RX.. **Cut off from flexible plastics**
 Trancher des plastiques flexibles

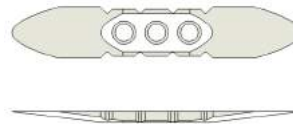

Seiten Pages: 17 - 20

Abstechen - Cutting off - Tronçonnage

KP-2-7..12°/.. **Abschneiden von flexiblen Kunststoffen**
KP-2-9..12°/.. **Cut off from flexible plastics**
 Trancher des plastiques flexibles

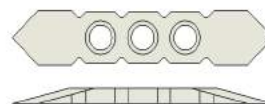

Seiten Pages: 21 - 24

Abstechen - Cutting off - Tronçonnage

KP-2-7..12°-VG.. **Abschneiden von flexiblen Kunststoffen**
KP-2-9..12°-VG.. **Cut off from flexible plastics**
 Trancher des plastiques flexibles

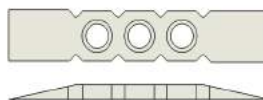

Seiten Pages: 25 - 28

Kopierdrehen-Copying tools-Outils de decolletage

KP-2-7..R02/R04..
KP-2-7..P-R02/R04..

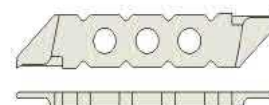

Seiten Pages: 29 - 30

Kopierdrehen-Copying tools-Outils de decolletage

KP-VCGT-16-S

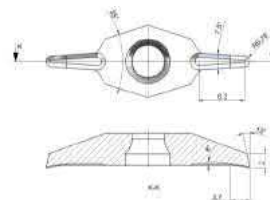

Seiten Pages: 31 - 32

Aussenbearbeitung - External machining - Usinage extérieur

Kopierdrehen-Copying tools-Outils de decolletage

KP-VCGT-11-S

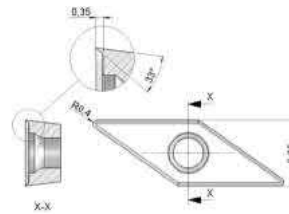

Seiten Pages: 33 - 34

Bearbeitungsbeispiele mit KP-2-7./KP-2-9.. HM-Profilplatten

Machining examples with profiled KP-2-7./KP-2-9.. carbide inserts

Exemples d'usinage avec plaquettes de profil en carbure monobloc KP-2-7./KP-2-9..

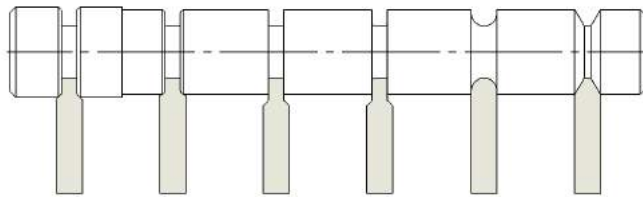

Seiten Pages: 35 - 38

Kopierdrehen-Copying tools-Outils de decolletage

System =SDAC-35°= VC..07..ISO-35° I.K.-I.C. 3.97

Halter/Holder/Porte-outils SDAC-0735..

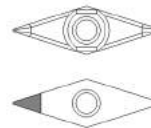

Seiten Pages: 39 - 40

Kopierdrehen-Copying tools-Outils de decolletage

System =SDAC-35°= VC..11..ISO-35° I.K.-I.C. 6.35

Halter/Holder/Porte-outils SDAC-1135..

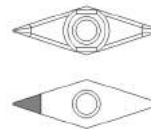

Seiten Pages: 41 - 42

Kopierdrehen-Copying tools-Outils de decolletage

System =SDAC-35°= VC..13..ISO-35° I.K.-I.C. 7.94

Halter/Holder/Porte-outils SDAC-1335..

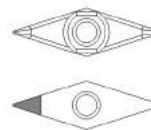

Seiten Pages: 43 - 44

Kopierdrehen-Copying tools-Outils de decolletage

System =SDAC-35°= VC..16..ISO-35° I.K.-I.C. 9.525

Halter/Holder/Porte-outils SDAC-1635..

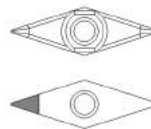

Seiten Pages: 45 - 46

Kopierdrehen-Copying tools-Outils de decolletage

System =SDAC-35°= VC..11..ISO-35° I.K.-I.C. 6.35

Halter/Holder/Porte-outils SDAC-275-1135..

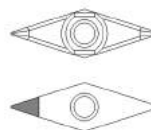

Seiten Pages: 47 - 48

Kopierdrehen-Copying tools-Outils de decolletage

System =SDAC-55°= DC..07..ISO-55° I.K.-I.C. 6.35

Halter/Holder/Porte-outils SDAC-0755..

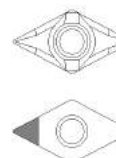

Seiten Pages: 49 - 50

Aussenbearbeitung - External machining - Usinage extérieur

Kopierdrehen-Copying tools-Outils de decolletage

System =SDAC-55°= DC..11..ISO-55° I.K.-I.C. 9.525

Halter/Holder/Porte-outils SDAC-1155..

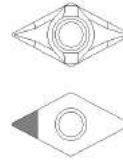

Seiten Pages: 51 - 52

Langdrehen-Long-turning-Chariotage

System =SLHC-06= CC..06..ISO-80° I.K.-I.C. 6.35

Halter/Holder/Porte-outils SLHC-06..



Seiten Pages: 53 - 54

Langdrehen-Long-turning-Chariotage

System =STAC=

Halter/Holder/Porte-outils STAC..

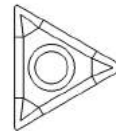

Seiten Pages: 55 - 56

Kopierdrehen-Copying tools-Outils de decolletage

System =SSAC-90=

Halter/Holder/Porte-outils SSAC-90..



Seiten Pages: 57 - 58

Außengewindestrehlen 55°/60°

External threading 55°/60°
Filetage extérieur 55°/60°

System =NL/AL=



Seiten Pages: 59 - 60

Technische Angaben-Technical Details-Données techniques

Hartmetallsorten -
Carbide grades -
Nuances des carbure -

Anwendungsempfehlung
Recommended for:
Recommandé pour:

Spanleitstufengeometrie -
Chip breaker geometry -
Géométrie de guide-copeaux -

Anwendungsempfehlung
Recommended for:
Recommandé pour:

PKD CBN -
PKD CBN -
PKD CBN -
Anwendungsempfehlung
Recommended for:
Recommandé pour:

Beschichtung -
Coating -
Revêtement -
Anwendungsempfehlung
Recommended for:
Recommandé pour:

Seiten Pages: 61 - 63

Weitere Dieterle Produkte-
More Dieterle products
Plus de Dieterle produits

Seite Page: 64 -66

Universal-System für Kunststoffbearbeitung
 Universal system for plastic machining
 Système universel pour le traitement plastique

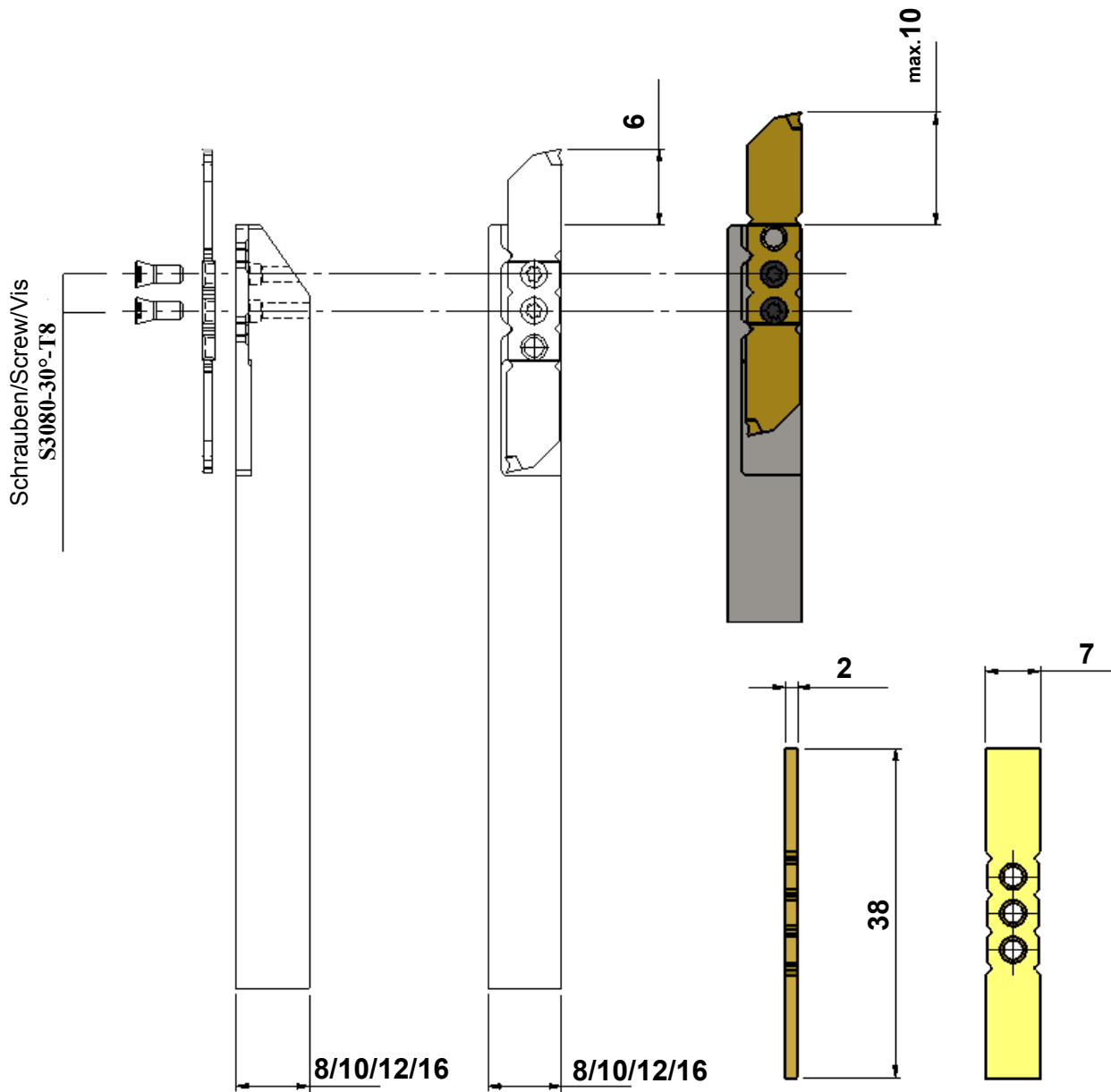

Rechtsausführung gezeichnet
 Right-hand version shown
 Exécution représentée à droite

VHM-Rohling
 Solid carbide blanks
 Ebauches en carbure monobloc

KP-2-7-UFK2-RO

Universal-System für Kunststoffbearbeitung
 Universal system for plastic machining
 Système universel pour le traitement plastique

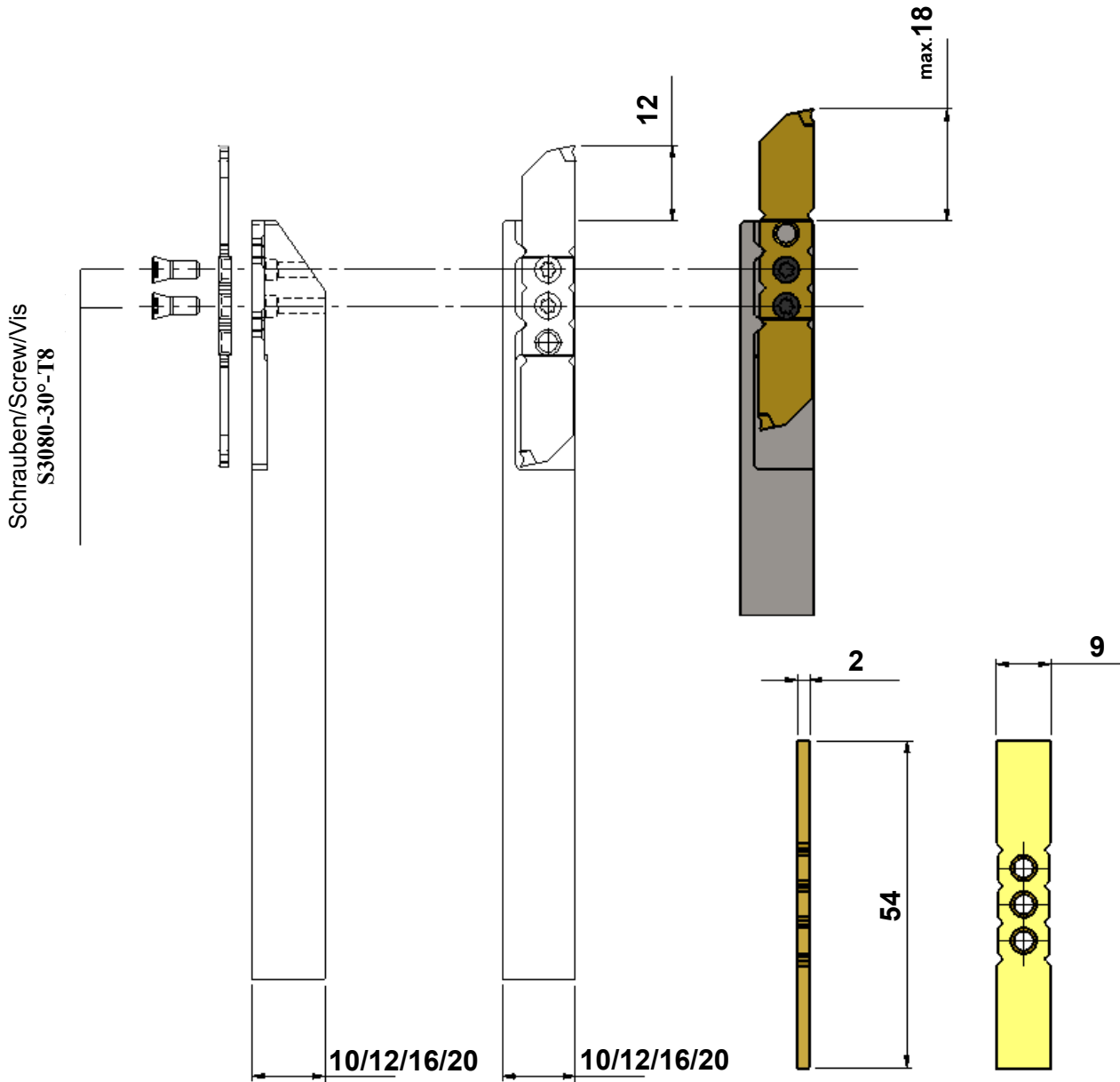

Rechtsausführung gezeichnet
 Right-hand version shown
 Exécution représentée à droite

VHM-Rohling
 Solid carbide blanks
 Ebauches en carbure monobloc

KP-2-9-UFK2-RO

Abstechen-Cutting off-Tronçonnage

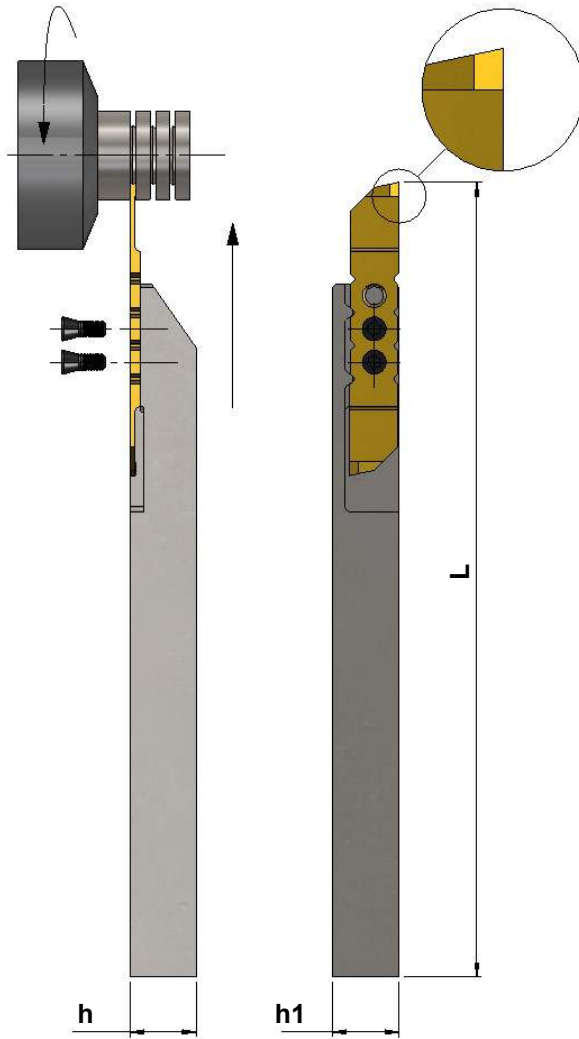

Bestellbezeichnung / Order number / No. de commande

Halter / Holder / Porte-outils	h	h1	L
KH-2-7-0808-L/R	8	8	140
KH-2-7-1010-L/R	10	10	140
KH-2-7-1212-L/R	12	12	140
KH-2-7-1616-L/R	16	16	125

Schlüssel/Key/Clef

Schraube/Screw/Vis



T8

S 3080-30°- KP

Rechter Halter rechte Platte
Right-hand holder right-hand insert
Porte-outil droite Plaquette droite

Linker Halter linke Platte
Left-hand holder left-hand insert
Porte-outil gauche Plaquette gauche

Rechtsausführung gezeichnet
Right-hand version shown
Exécution représentée à droite

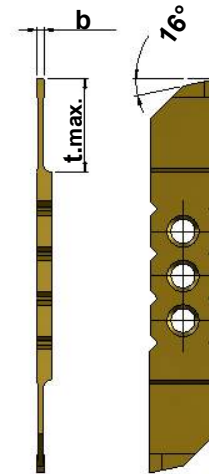

Bestellbezeichnung / Order number / No. de commande

L	R	HM-Wendepplatten Carbide inserts /Plaquettes réversibles	Unbeschichtet	PKD	b	t _{max}
O	O	KP-2-7-08-6-S1-L/R	UFK-2		0,8	6,0
O	O	KP-2-7-08-10-S1-L/R	UFK-2		0,8	10
O	O	KP-2-7-10-10-S1-L/R	UFK-2		1,0	10
O	O	KP-2-7-15-10-S1-L/R	UFK-2		1,5	10

O = Ab Lager
Ex stock
En magasin



=

Auf Anfrage
on request
sur demande

Abstechen-Cutting off-Tronçonnage

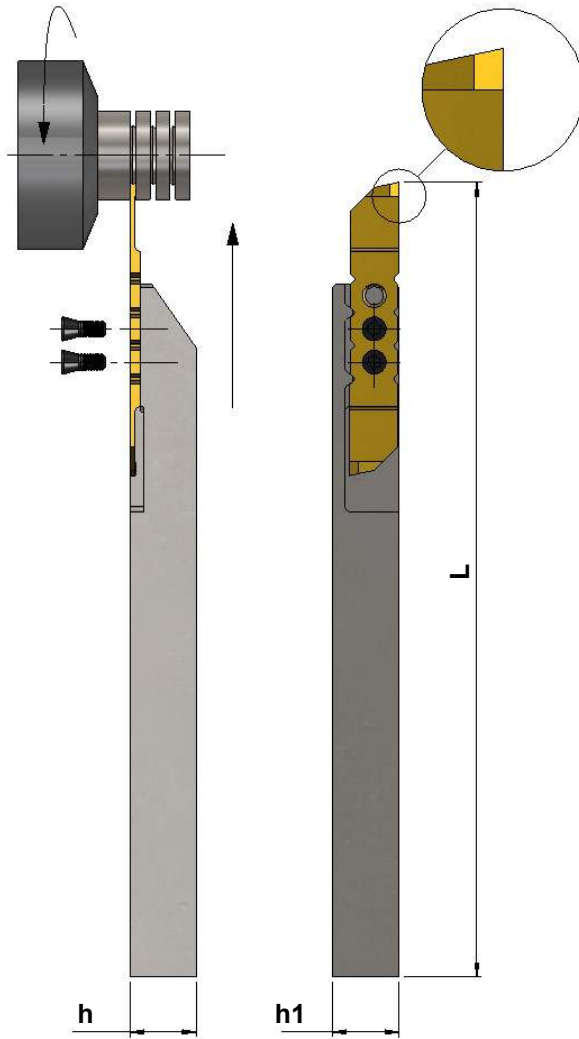

Bestellbezeichnung / Order number / No. de commande

Halter / Holder / Porte-outils	h	h1	L
KH-2-1010-L/R	10	10	140
KH-2-1212-L/R	12	12	140
KH-2-1616-L/R	16	16	125
KH-2-2020-L/R	20	20	125

Schlüssel/Key/Clef

Schraube/Screw/Vis



T8

S 3080-30°- KP

Rechter Halter rechte Platte
Right-hand holder right-hand insert
Porte-outil droite Plaquette droite

Linker Halter linke Platte
Left-hand holder left-hand insert
Porte-outil gauche Plaquette gauche

Rechtsausführung gezeichnet
Right-hand version shown

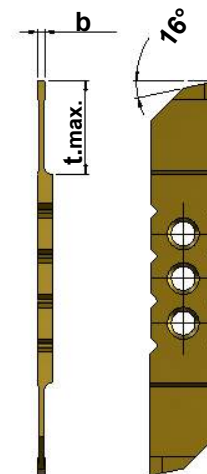

Bestellbezeichnung / Order number / No. de commande

L	R	HM-Wendeplatten Carbide inserts /Plaquettes réversibles	Unbeschichtet	PKD	b	t _{max}
O	O	KP-2-9-08-12-S1-L/R	UFK-2		0,8	12
O	O	KP-2-9-08-16-S1-L/R	UFK-2		0,8	16
O	O	KP-2-9-10-12-S1-L/R	UFK-2		1,0	12
O	O	KP-2-9-10-16-S1-L/R	UFK-2		1,0	16
O	O	KP-2-9-15-18-S1-L/R	UFK-2		1,5	18
O	O	KP-2-9-20-18-S1-L/R	UFK-2		2,0	18

O = Ab Lager
Ex stock
En magasin



=

Auf Anfrage
on request
sur demande

Abstechen-Cutting off-Tronçonnage

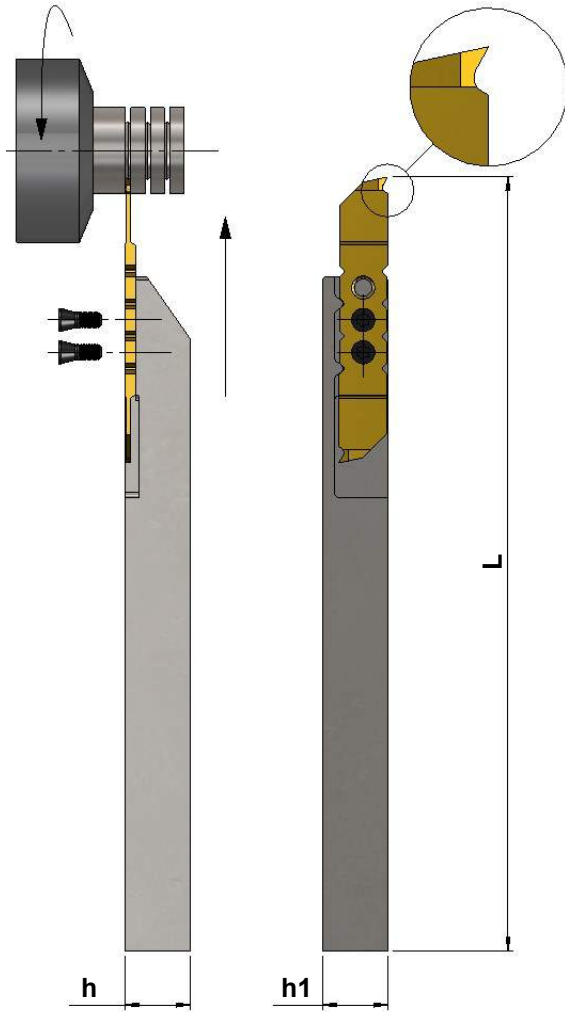

Rechtsausführung gezeichnet
Right-hand version shown
Exécution représentée à droite

Bestellbezeichnung / Order number / No. de commande

Halter / Holder / Porte-outils	h	h1	L
KH-2-7-0808-L/R	8	8	140
KH-2-7-1010-L/R	10	10	140
KH-2-7-1212-L/R	12	12	140
KH-2-7-1616-L/R	16	16	125

Schlüssel/Key/Clef

Schraube/Screw/Vis



T8

S 3080-30°- KP

Rechter Halter rechte Platte
Right-hand holder right-hand insert
Porte-outil droite Plaquette droite

Linker Halter linke Platte
Left-hand holder left-hand insert
Porte-outil gauche Plaquette gauche

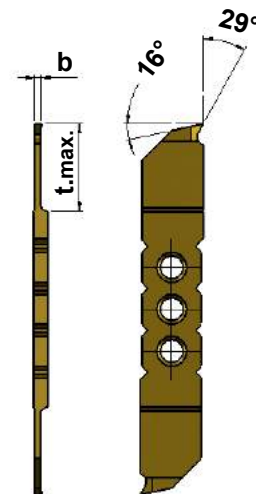

Bestellbezeichnung / Order number / No. de commande

L	R	HM-Wendeplatten Carbide inserts /Plaquettes réversibles	Unbeschichtet	b	t _{max}
O	O	KP-2-7-08-6-S1-SP-L/R	UFK-2	0,8	6,0
O	O	KP-2-7-08-10-S1-SP-L/R	UFK-2	0,8	10
O	O	KP-2-7-10-10-S1-SP-L/R	UFK-2	1,0	10
O	O	KP-2-7-15-10-S1-SP-L/R	UFK-2	1,5	10

O = Ab Lager
Ex stock
En magasin

Abstechen-Cutting off-Tronçonnage

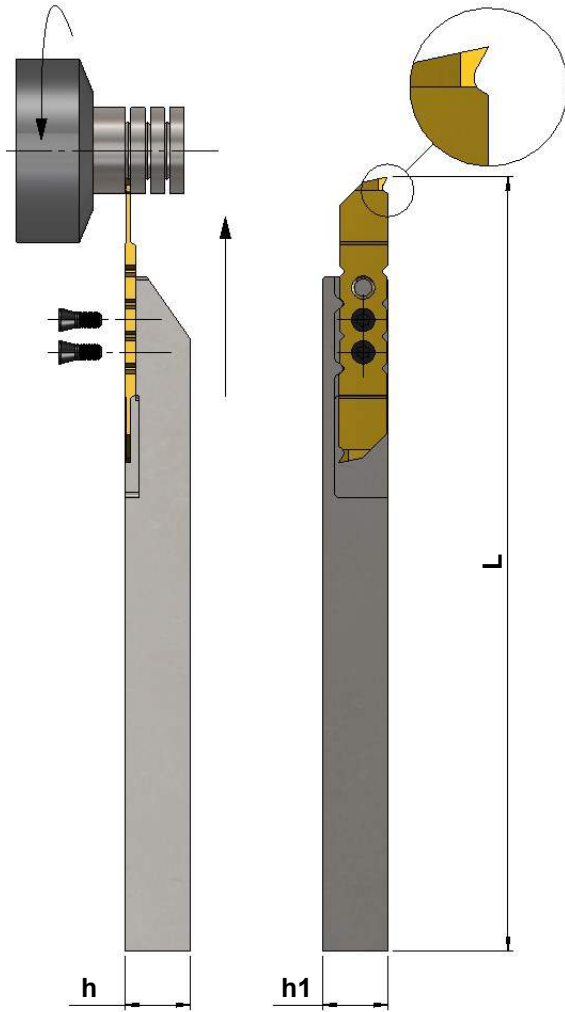

Rechtsausführung gezeichnet
Right-hand version shown
Exécution représentée à droite

Bestellbezeichnung / Order number / No. de commande

Halter / Holder / Porte-outils	h	h1	L
KH-2-1010-L/R	10	10	140
KH-2-1212-L/R	12	12	140
KH-2-1616-L/R	16	16	125
KH-2-2020-L/R	20	20	125

Schlüssel/Key/Clef

Schraube/Screw/Vis



T8



S 3080-30°- KP

Rechter Halter rechte Platte
Right-hand holder right-hand insert
Porte-outil droite Plaquette droite

Linker Halter linke Platte
Left-hand holder left-hand insert
Porte-outil gauche Plaquette gauche

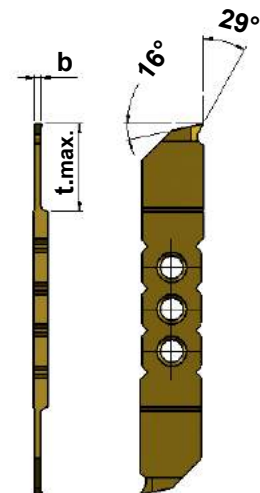

Bestellbezeichnung / Order number / No. de commande

L	R	HM-Wendeplatten Carbide inserts / Plaquettes réversibles	Unbeschichtet	b	t _{max}
O	O	KP-2-9-08-16-S1-SP-L/R	UFK-2	0,8	16
O	O	KP-2-9-10-16-S1-SP-L/R	UFK-2	1,0	16
O	O	KP-2-9-15-18-S1-SP-L/R	UFK-2	1,5	18
O	O	KP-2-9-20-18-S1-SP-L/R	UFK-2	2,0	18

O = Ab Lager
Ex stock
En magasin

Abstechen-Cutting off-Tronçonnage

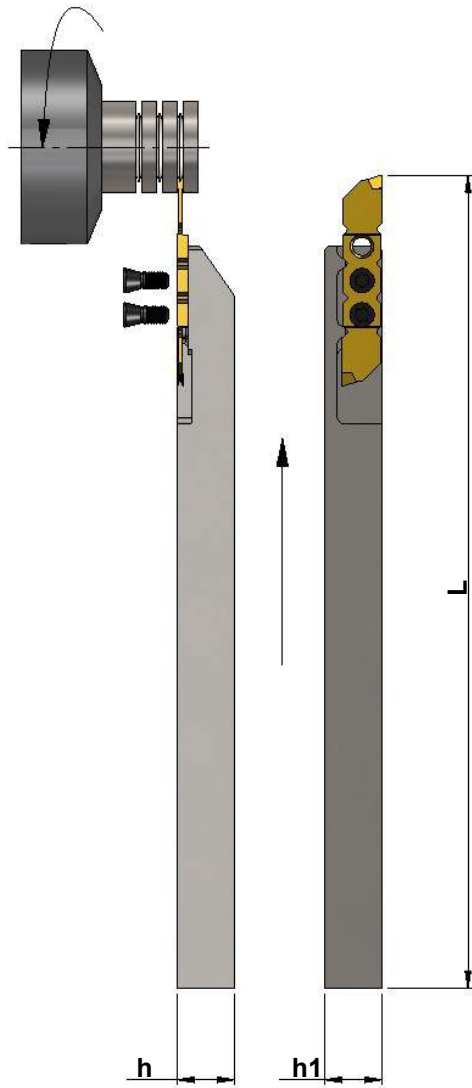

Rechtsausführung gezeichnet
Right-hand version shown
Exécution représentée à droite

Bestellbezeichnung /Order number /No. de commande

Halter / Holder / Porte-outils	h	h1	L
KH-2-7-0808-L/R	8	8	140
KH-2-7-1010-L/R	10	10	140
KH-2-7-1212-L/R	12	12	140
KH-2-7-1616-L/R	16	16	125

Schlüssel/Key/Clef

Schraube/Screw/Vis



T8

S 3080-30°- KP

Rechter Halter rechte Platte
Right-hand holder right-hand insert
Porte-outil droite Plaquette droite

Linker Halter linke Platte
Left-hand holder left-hand insert
Porte-outil gauche Plaquette gauche

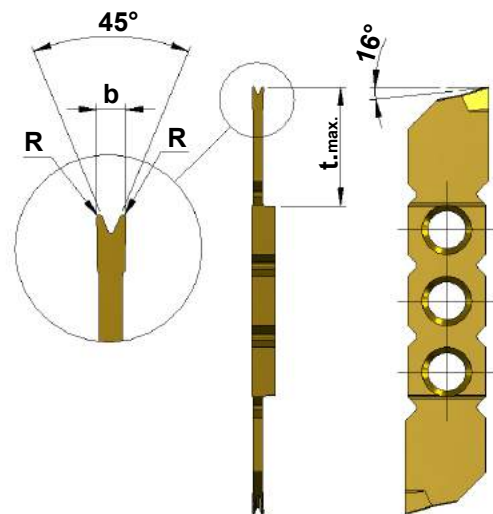

Bestellbezeichnung / Order number / No. de commande

L	R	HM-Wendeplatten Carbide inserts /Plaquettes réversibles	Unbeschichtet	b	t _{max}	R
O	O	KP-2-7-10-5-45°-01-L/R	UFK-2	1,0	5	0,1
O	O	KP-2-7-10-10-45°-01-L/R	UFK-2	1,0	10	0,1
O	O	KP-2-7-15-10-45°-01-L/R	UFK-2	1,5	10	0,1

O = Ab Lager
Ex stock
En magasin

Abstechen-Cutting off-Tronçonnage

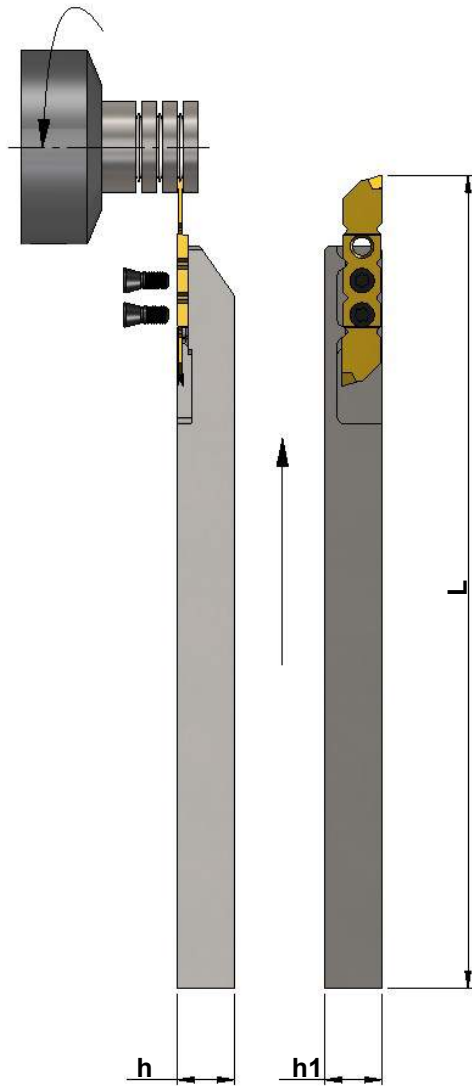

Rechtsausführung gezeichnet
Right-hand version shown
Exécution représentée à droite

Bestellbezeichnung / Order number / No. de commande

Halter / Holder / Porte-outils	h	h1	L
KH-2-1010-L/R	10	10	140
KH-2-1212-L/R	12	12	140
KH-2-1616-L/R	16	16	125
KH-2-2020-L/R	20	20	125

Schlüssel/Key/Clef

Schraube/Screw/Vis



T8

S 3080-30°- KP

Rechter Halter rechte Platte
Right-hand holder right-hand insert
Porte-outil droite Plaquette droite

Linker Halter linke Platte
Left-hand holder left-hand insert
Porte-outil gauche Plaquette gauche

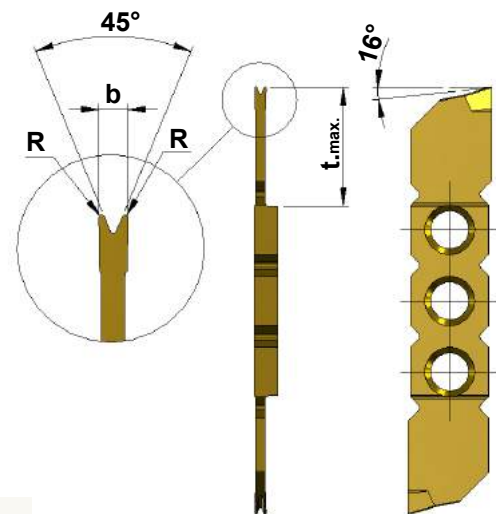

Bestellbezeichnung / Order number / No. de commande

L	R	HM-Wendepplatten Carbide inserts / Plaquettes réversibles	Unbeschichtet	b	t _{max}	R
O	O	KP-2-9-10-12-45°-01-L/R	UFK-2	1,0	12	0,1
O	O	KP-2-9-10-18-45°-01-L/R	UFK-2	1,0	18	0,1
O	O	KP-2-9-15-12-45°-01-L/R	UFK-2	1,5	12	0,1
O	O	KP-2-9-15-18-45°-01-L/R	UFK-2	1,5	18	0,1
O	O	KP-2-9-20-12-45°-01-L/R	UFK-2	2,0	12	0,1
O	O	KP-2-9-20-18-45°-01-L/R	UFK-2	2,0	18	0,1
O	O	KP-2-9-15-16-45°-L/R-R0,2	UFK-2	1,5	16	0,2

Ab Lager
O = Ex stock
En magasin

Abstechen-Cutting off-Tronçonnage

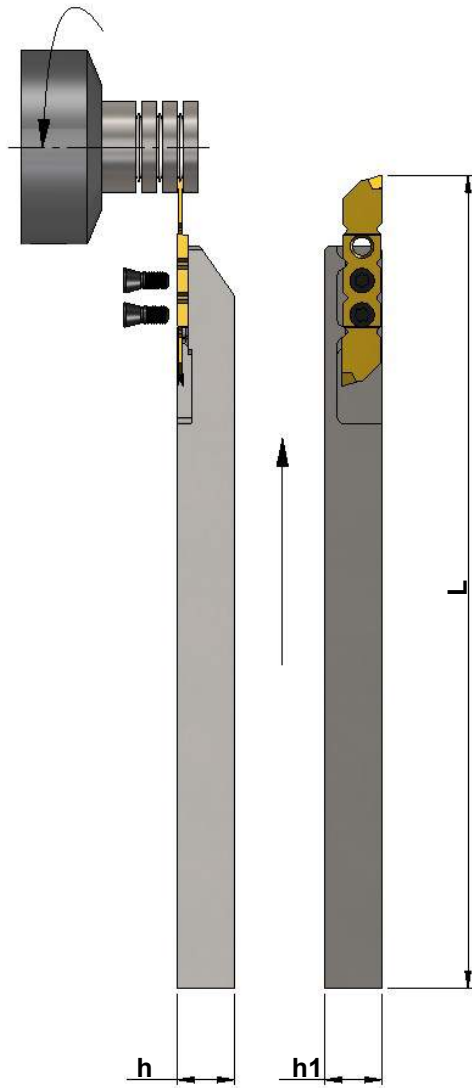

Rechtsausführung gezeichnet
Right-hand version shown
Exécution représentée à droite

Bestellbezeichnung /Order number /No. de commande

Halter / Holder / Porte-outils	h	h1	L
KH-2-7-0808-L/R	8	8	140
KH-2-7-1010-L/R	10	10	140
KH-2-7-1212-L/R	12	12	140
KH-2-7-1616-L/R	16	16	125

Schlüssel/Key/Clef

Schraube/Screw/Vis



T8

S 3080-30°- KP

Rechter Halter rechte Platte
Right-hand holder right-hand insert
Porte-outil droite Plaquette droite

Linker Halter linke Platte
Left-hand holder left-hand insert
Porte-outil gauche Plaquette gauche

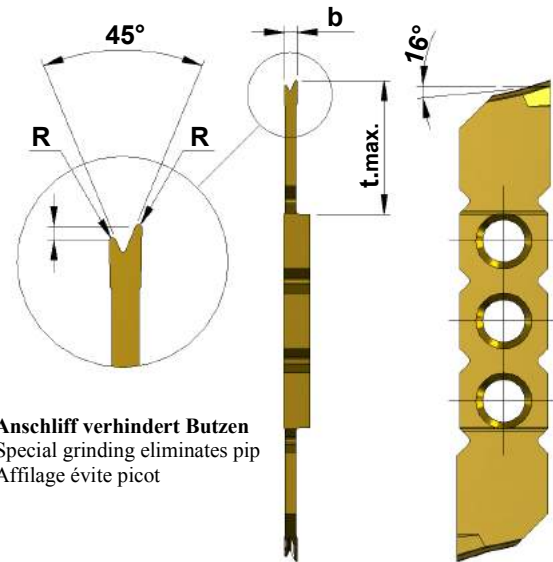

Anschliff verhindert Butzen
Special grinding eliminates pip
Affilage évite picot

Bestellbezeichnung / Order number / No. de commande

L	R	HM-Wendeplatten Carbide inserts /Plaquettes réversibles	Unbeschichtet	b	t _{max}	R
O	O	KP-2-7-10-5-45°-S-01-L/R	UFK-2	1,0	5	0,1
O	O	KP-2-7-10-10-45°-S-01-L/R	UFK-2	1,0	10	0,1
O	O	KP-2-7-15-10-45°-S-01-L/R	UFK-2	1,5	10	0,1

O = Ab Lager
Ex stock
En magasin

Abstechen-Cutting off-Tronçonnage

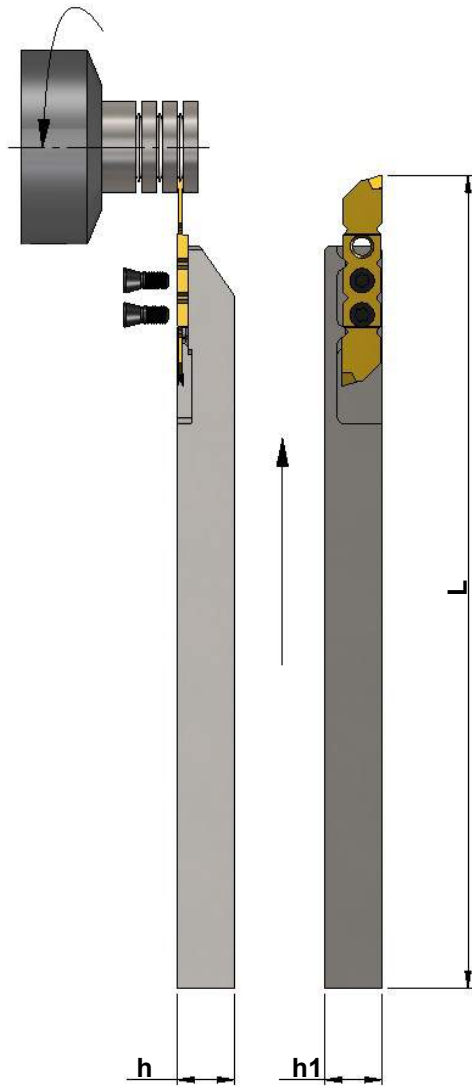

Rechtsausführung gezeichnet
Right-hand version shown
Exécution représentée à droite

Bestellbezeichnung / Order number / No. de commande

Halter / Holder / Porte-outils	h	h1	L
KH-2-1010-L/R	10	10	140
KH-2-1212-L/R	12	12	140
KH-2-1616-L/R	16	16	125
KH-2-2020-L/R	20	20	125

Schlüssel/Key/Clef

Schraube/Screw/Vis



T8



S 3080-30°- KP

Rechter Halter rechte Platte
Right-hand holder right-hand insert
Porte-outil droite Plaquette droite

Linker Halter linke Platte
Left-hand holder left-hand insert
Porte-outil gauche Plaquette gauche

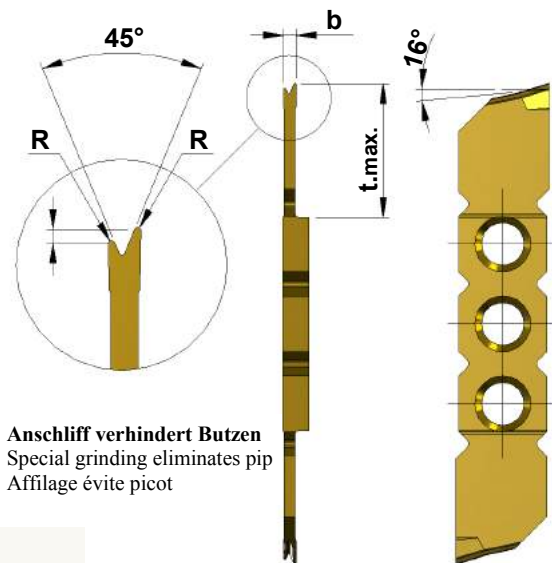

Anschliff verhindert Butzen
Special grinding eliminates pip
Affilage évite picot

Bestellbezeichnung / Order number / No. de commande

L	R	HM-Wendeplatten Carbide inserts / Plaquettes réversibles	Unbeschichtet	b	tmax	R
O	O	KP-2-9-10-12-45°-S-01-L/R	UFK-2	1,0	12	0,1
O	O	KP-2-9-10-18-45°-S-01-L/R	UFK-2	1,0	18	0,1
O	O	KP-2-9-15-12-45°-S01-L/R	UFK-2	1,5	12	0,1
O	O	KP-2-9-15-18-45°-S-01-L/R	UFK-2	1,5	18	0,1
O	O	KP-2-9-20-12-45°-S-01-L/R	UFK-2	2,0	12	0,1
O	O	KP-2-9-20-18-45°-S-01-L/R	UFK-2	2,0	18	0,1

O = Ab Lager
Ex stock
En magasin

Abstechen von flexiblen Kunststoffen

Cut off from flexible plastics

Trancher des plastiques flexibles

Bestellbezeichnung / Order number / No. de commande

Halter / Holder / Porte-outils	h	h1	L
KH-2-7-0808-L/R	8	8	140
KH-2-7-1010-L/R	10	10	140
KH-2-7-1212-L/R	12	12	140
KH-2-7-1616-L/R	16	16	125

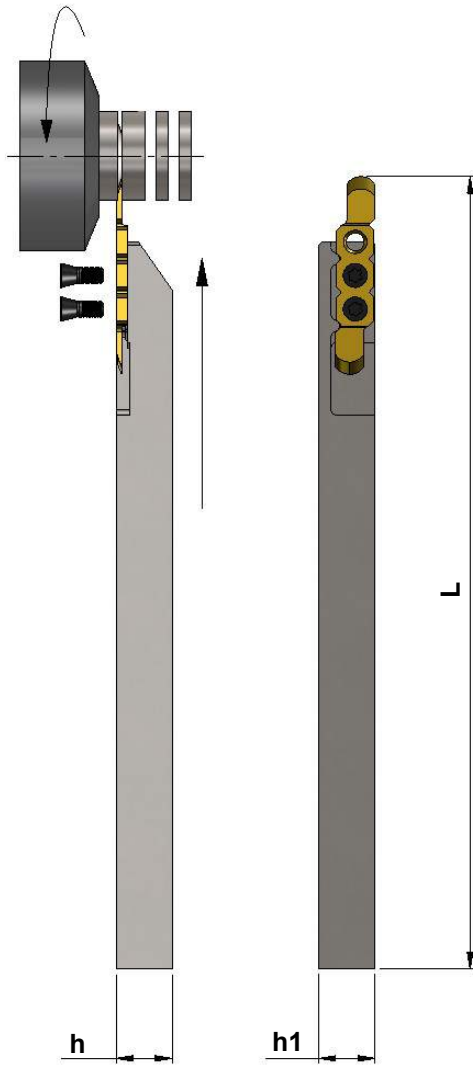

Schlüssel/Key/Clef

Schraube/Screw/Vis



T8

S 3080-30°- KP

Rechter Halter rechte Platte
Right-hand holder right-hand insert
Porte-outil droite Plaquette droite

Linker Halter linke Platte
Left-hand holder left-hand insert
Porte-outil gauche Plaquette gauche

Rechtsausführung gezeichnet
Right-hand version shown
Exécution représentée à droite

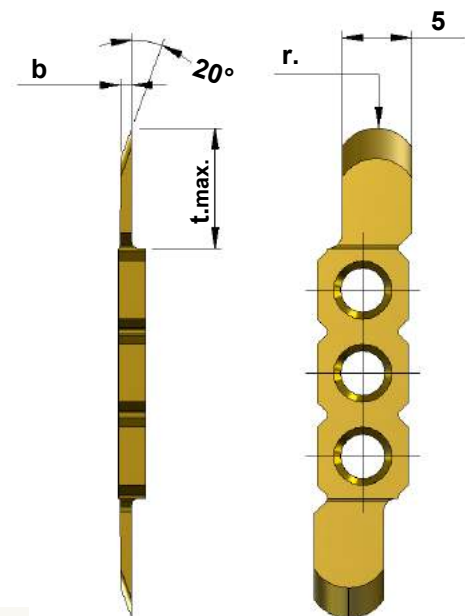

Bestellbezeichnung / Order number / No. de commande

L	R	HM-Wendeplatten Carbide inserts /Plaquettes réversibles	Unbeschichtet	b	t _{max}	r.
O	O	KP-2-7-08-R3-8-L/R	UFK-2	0,8	8,0	3,0

O = Ab Lager
Ex stock
En magasin

Abstechen von flexiblen Kunststoffen Cut off from flexible plastics Trancher des plastiques flexibles

Bestellbezeichnung / Order number / No. de commande

Halter / Holder / Porte-outils	h	h1	L
KH-2-1010-L/R	10	10	140
KH-2-1212-L/R	12	12	140
KH-2-1616-L/R	16	16	125
KH-2-2020-L/R	20	20	125

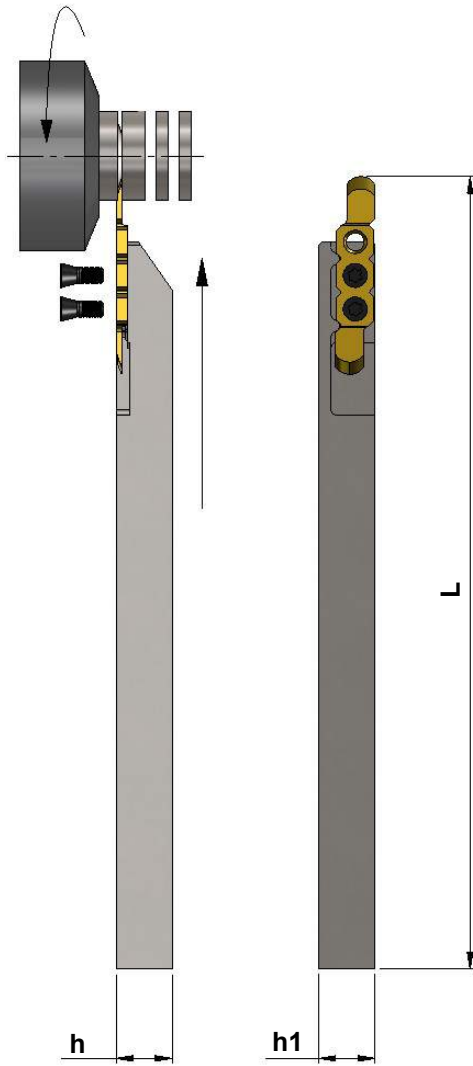

Schlüssel/Key/Clef

Schraube/Screw/Vis



T8

S 3080-30°- KP

Rechter Halter rechte Platte
Right-hand holder right-hand insert
Porte-outil droite Plaquette droite

Linker Halter linke Platte
Left-hand holder left-hand insert
Porte-outil gauche Plaquette gauche

Rechtsausführung gezeichnet
Right-hand version shown
Exécution représentée à droite

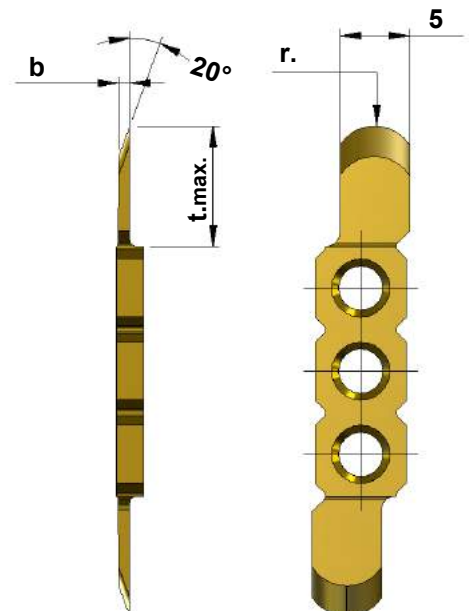

Bestellbezeichnung / Order number / No. de commande

L	R	HM-Wendepplatten Carbide inserts /Plaquettes réversibles	Unbeschichtet	b	t _{max}	r.
O	O	KP-2-9-08-R3-12-L/R	UFK-2	0,8	12	3,0
O	O	KP-2-9-08-R3-16-L/R	UFK-2	0,8	16	3,0

O = Ab Lager
Ex stock
En magasin

Abstechen von flexiblen Kunststoffen Cut off from flexible plastics Trancher des plastiques flexibles

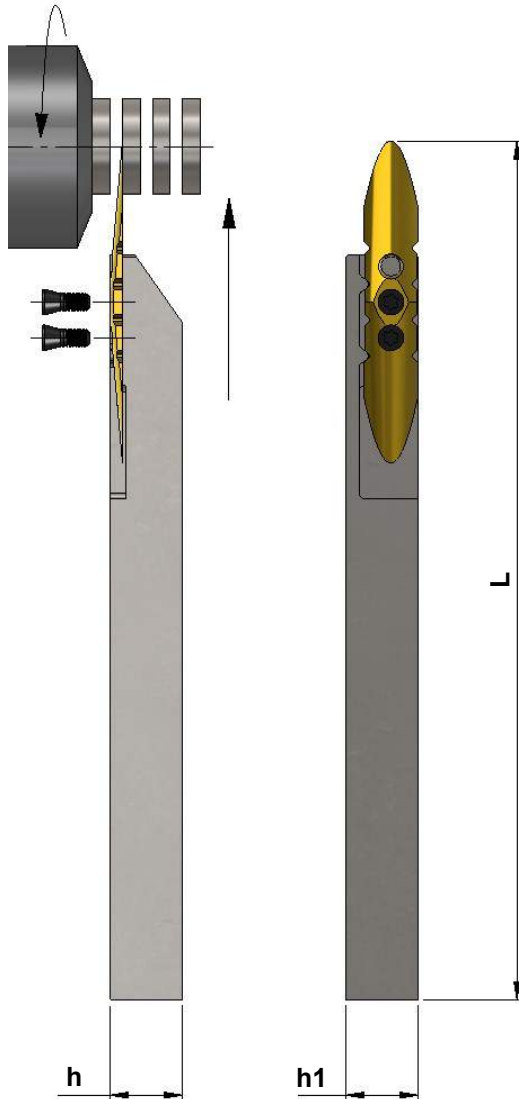

Rechtsausführung gezeichnet
Right-hand version shown
Exécution représentée à droite

Bestellbezeichnung / Order number / No. de commande

Halter / Holder / Porte-outils	h	h1	L
KH-2-7-0808-L/R	8	8	140
KH-2-7-1010-L/R	10	10	140
KH-2-7-1212-L/R	12	12	140
KH-2-7-1616-L/R	16	16	125

Schlüssel/Key/Clef



T8

Schraube/Screw/Vis



S 3080-30°- KP

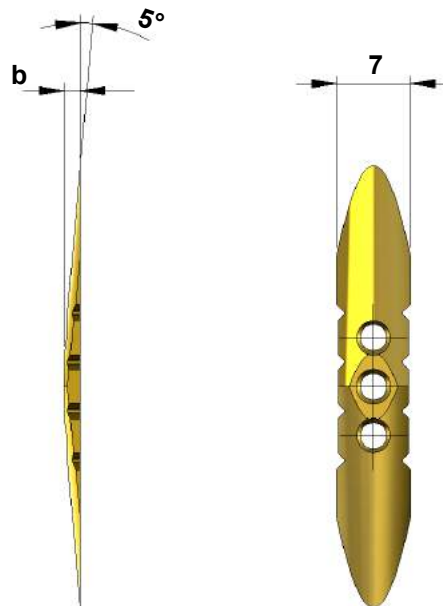

Bestellbezeichnung / Order number / No. de commande

L(R)	HM-Wendeplatten Carbide inserts /Plaquettes réversibles	Unbeschichtet	b	t _{max}
O	KP-2-7-RX-A	UFK-2	2.0	12

O = Ab Lager
Ex stock
En magasin

Abstechen von flexiblen Kunststoffen Cut off from flexible plastics Trancher des plastiques flexibles

Bestellbezeichnung / Order number / No. de commande

Halter / Holder / Porte-outils	h	h1	L
KH-2-7-0808-L/R	8	8	140
KH-2-7-1010-L/R	10	10	140
KH-2-7-1212-L/R	12	12	140
KH-2-7-1616-L/R	16	16	125

Schlüssel/Key/Clef

Schraube/Screw/Vis



T8

S 3080-30°- KP

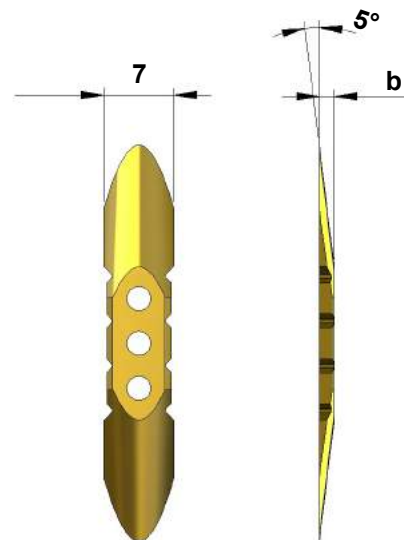
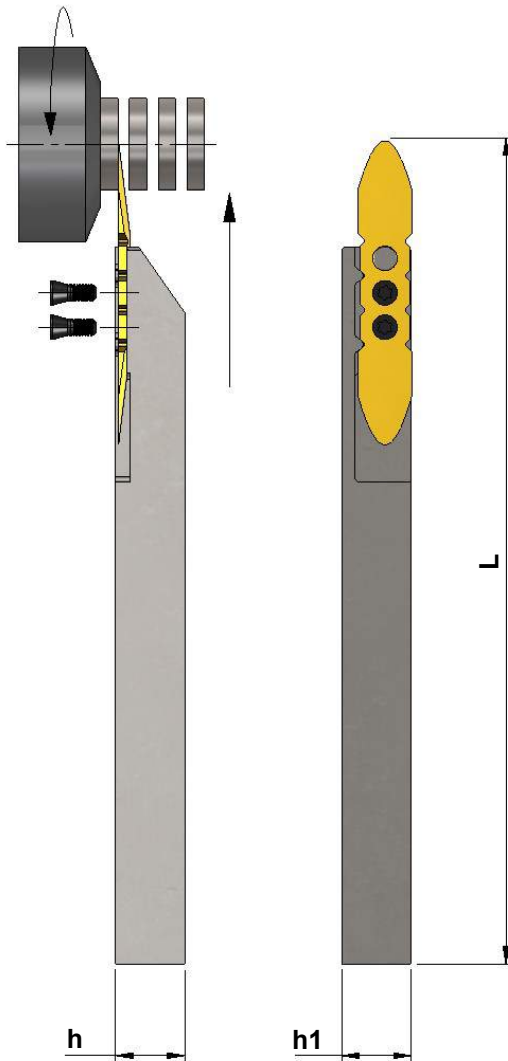

Rechtsausführung gezeichnet
Right-hand version shown
Exécution représentée à droite

Bestellbezeichnung / Order number / No. de commande

L(R)	HM-Wendeplatten Carbide inserts / Plaquettes réversibles	Unbeschichtet	b	t _{max}
O	KP-2-7-RX-B	UFK-2	2.0	12

O = Ab Lager
Ex stock
En magasin

Abstechen von flexiblen Kunststoffen

Cut off from flexible plastics

Trancher des plastiques flexibles

Bestellbezeichnung / Order number / No. de commande

Halter / Holder / Porte-outils	h	h1	L
KH-2-1010-L/R	10	10	140
KH-2-1212-L/R	12	12	140
KH-2-1616-L/R	16	16	125
KH-2-2020-L/R	20	20	125

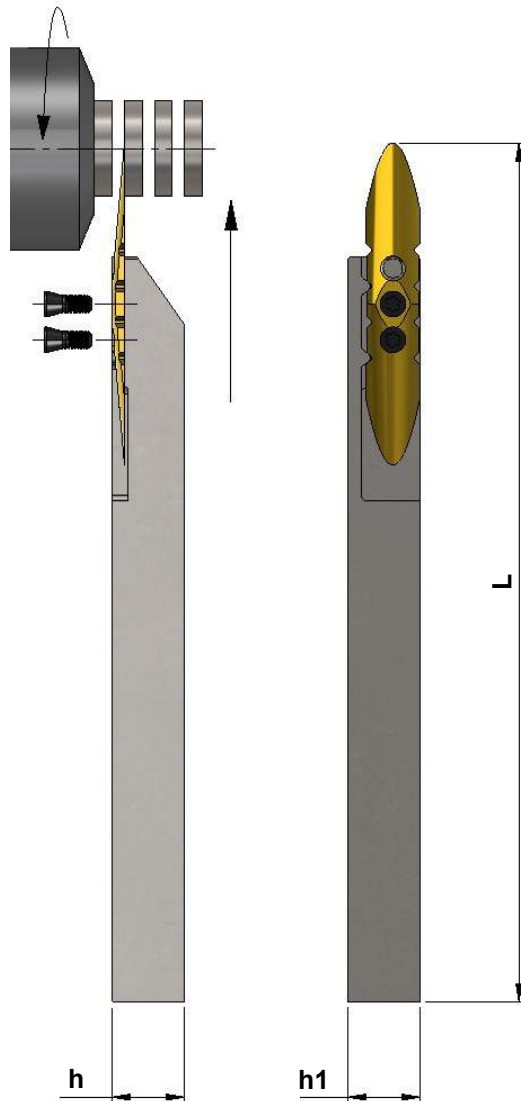

Schlüssel/Key/Clef

Schraube/Screw/Vis



T8

S 3080-30°- KP

Rechtsausführung gezeichnet
Right-hand version shown
Exécution représentée à droite

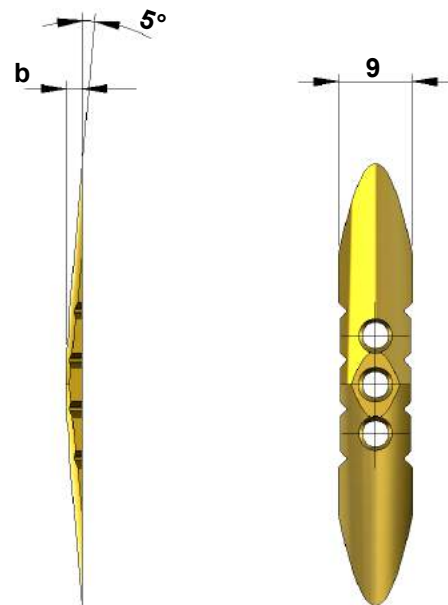

Bestellbezeichnung / Order number / No. de commande

L(R)	HM-Wendeplatten Carbide inserts / Plaquettes réversibles	Unbeschichtet	b	t _{max}
O	KP-2-9-RX-A	UFK-2	2.0	18

O = Ab Lager
Ex stock
En magasin

Abstechen von flexiblen Kunststoffen

Cut off from flexible plastics

Trancher des plastiques flexibles

Bestellbezeichnung / Order number / No. de commande

Halter / Holder / Porte-outils	h	h1	L
KH-2-1010-L/R	10	10	140
KH-2-1212-L/R	12	12	140
KH-2-1616-L/R	16	16	125
KH-2-2020-L/R	20	20	125

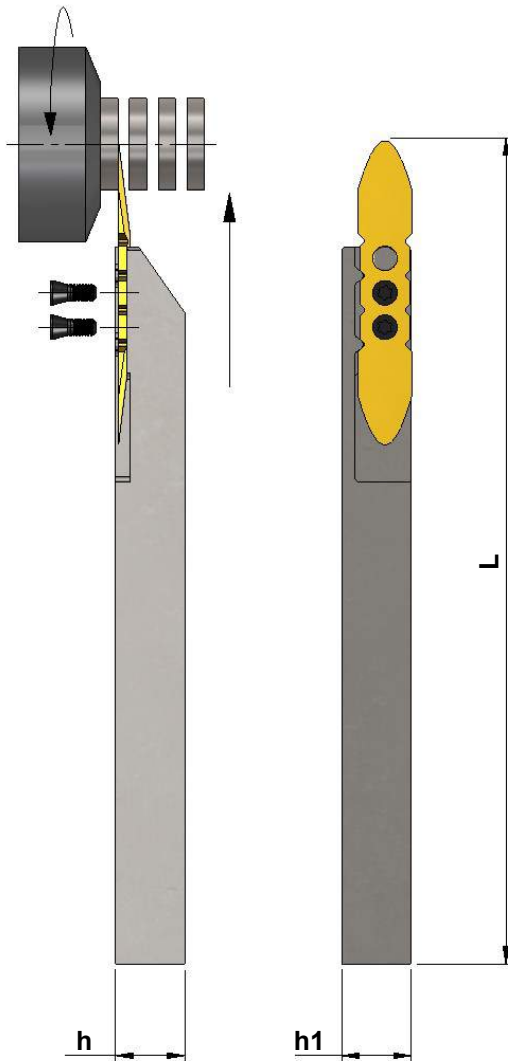

Schlüssel/Key/Clef

Schraube/Screw/Vis



T8

S 3080-30°- KP

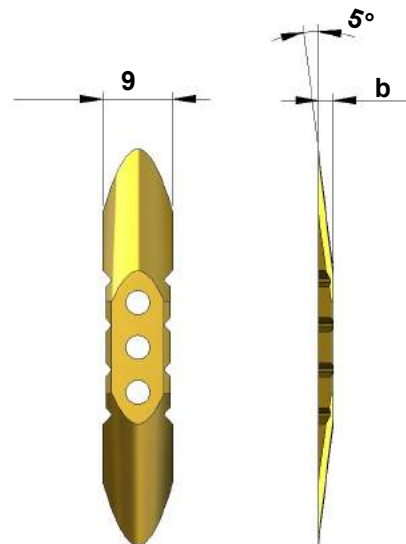

Rechtsausführung gezeichnet
Right-hand version shown
Exécution représentée à droite

Bestellbezeichnung / Order number / No. de commande

L(R)	HM-Wendeplatten Carbide inserts / Plaquettes réversibles	Unbeschichtet	b	t _{max}
O	KP-2-9-RX-B	UFK-2	2.0	18

O = Ab Lager
Ex stock
En magasin

Abstechen von flexiblen Kunststoffen

Cut off from flexible plastics

Trancher des plastiques flexibles

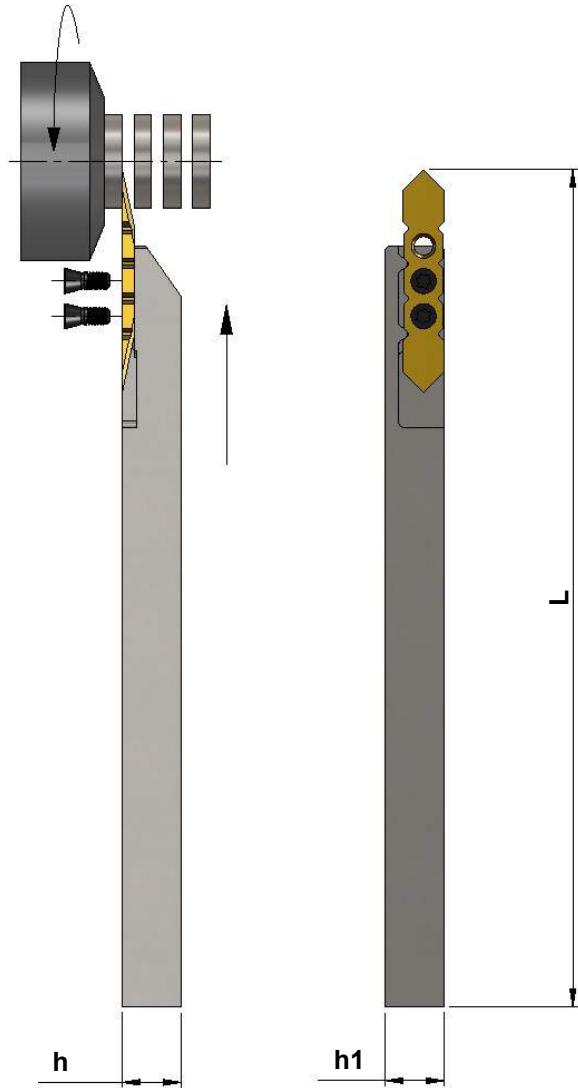

Bestellbezeichnung / Order number / No. de commande

Halter / Holder / Porte-outils	h	h1	L
KH-2-7-0808-L/R	8	8	140
KH-2-7-1010-L/R	10	10	140
KH-2-7-1212-L/R	12	12	140
KH-2-7-1616-L/R	16	16	125

Schlüssel/Key/Clef

Schraube/Screw/Vis



T8

S 3080-30°- KP

Rechtsausführung gezeichnet
Right-hand version shown
Exécution représentée à droite

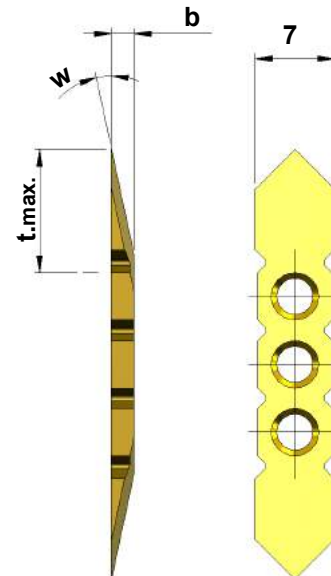

Bestellbezeichnung / Order number / No. de commande

L(R)	HM-Wendeplatten Carbide inserts /Plaquettes réversibles	Unbeschichtet	b	t _{max}	w
O	KP-2-7-12°-12-A	UFK-2	2,0	12	12°

O = Ab Lager
Ex stock
En magasin

Abstechen von flexiblen Kunststoffen

Cut off from flexible plastics

Trancher des plastiques flexibles

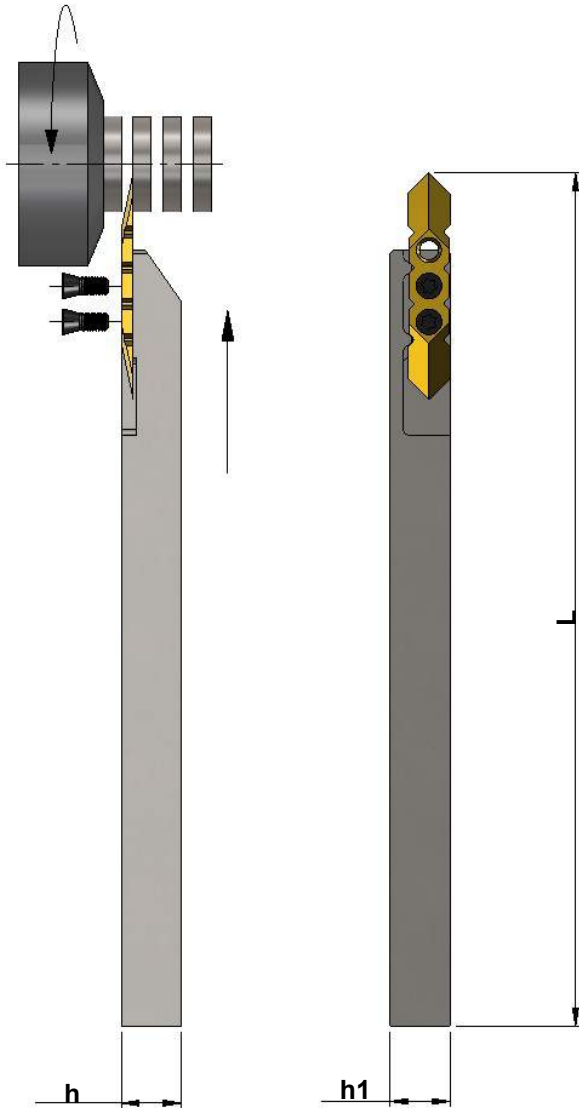

Bestellbezeichnung / Order number / No. de commande

Halter / Holder / Porte-outils	h	h1	L
KH-2-7-0808-L/R	8	8	140
KH-2-7-1010-L/R	10	10	140
KH-2-7-1212-L/R	12	12	140
KH-2-7-1616-L/R	16	16	125

Schlüssel/Key/Clef

Schraube/Screw/Vis



T8



S 3080-30°- KP

Rechtsausführung gezeichnet
Right-hand version shown
Exécution représentée à droite

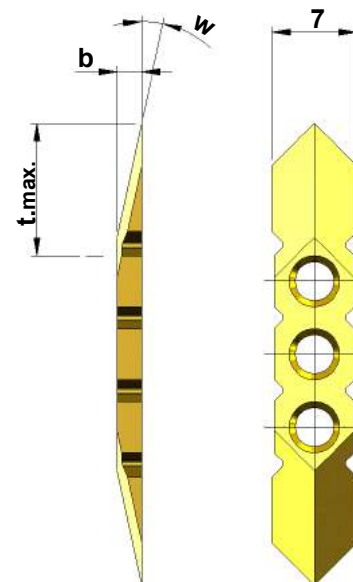

Bestellbezeichnung / Order number / No. de commande

L(R)	HM-Wendeplatten Carbide inserts /Plaquettes réversibles	Unbeschichtet	b	t _{max}	w
O	KP-2-7-12°-12-B	UFK-2	2,0	12	12°

O = Ab Lager
Ex stock
En magasin

Abstechen von flexiblen Kunststoffen

Cut off from flexible plastics

Trancher des plastiques flexibles

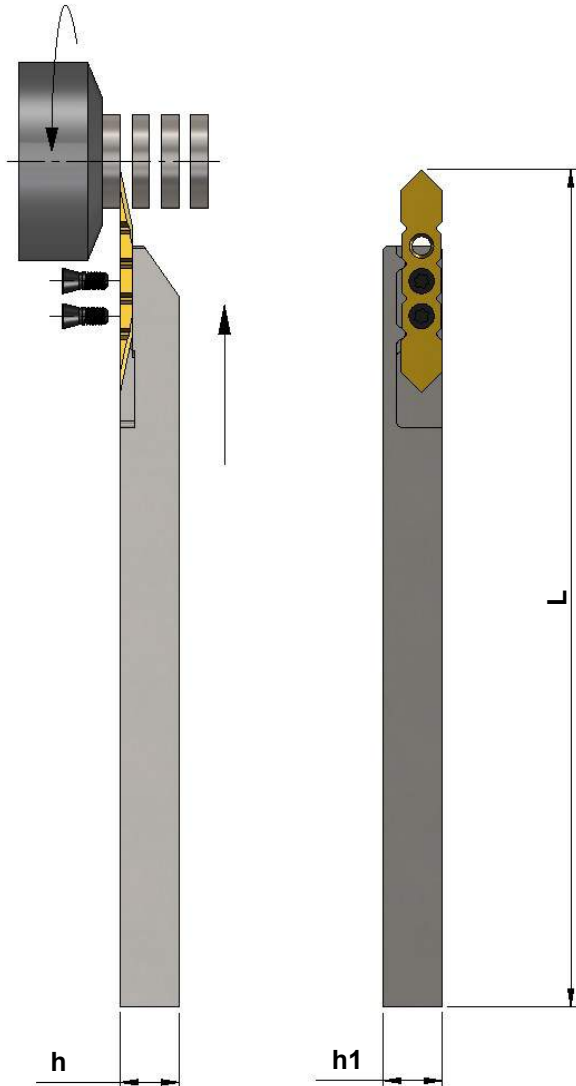
Bestellbezeichnung / Order number / No. de commande

Halter / Holder / Porte-outils	h	h1	L
KH-2-1010-L/R	10	10	140
KH-2-1212-L/R	12	12	140
KH-2-1616-L/R	16	16	125
KH-2-2020-L/R	20	20	125

Schlüssel/Key/Clef

Schraube/Screw/Vis



T8

S 3080-30°- KP

Rechtsausführung gezeichnet
 Right-hand version shown
 Exécution représentée à droite

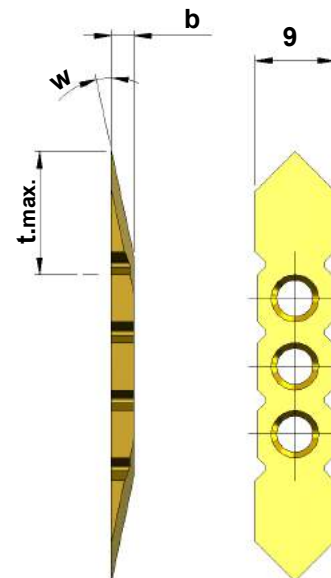
Bestellbezeichnung / Order number / No. de commande

L(R)	HM-Wendeplatten Carbide inserts / Plaquettes réversibles	Unbeschichtet	b	t _{max}	w
O	KP-2-9-12°-12-18-A	UFK-2	2,0	18	12°

Ab Lager
 O = Ex stock
 En magasin

Abstechen von flexiblen Kunststoffen

Cut off from flexible plastics

Trancher des plastiques flexibles

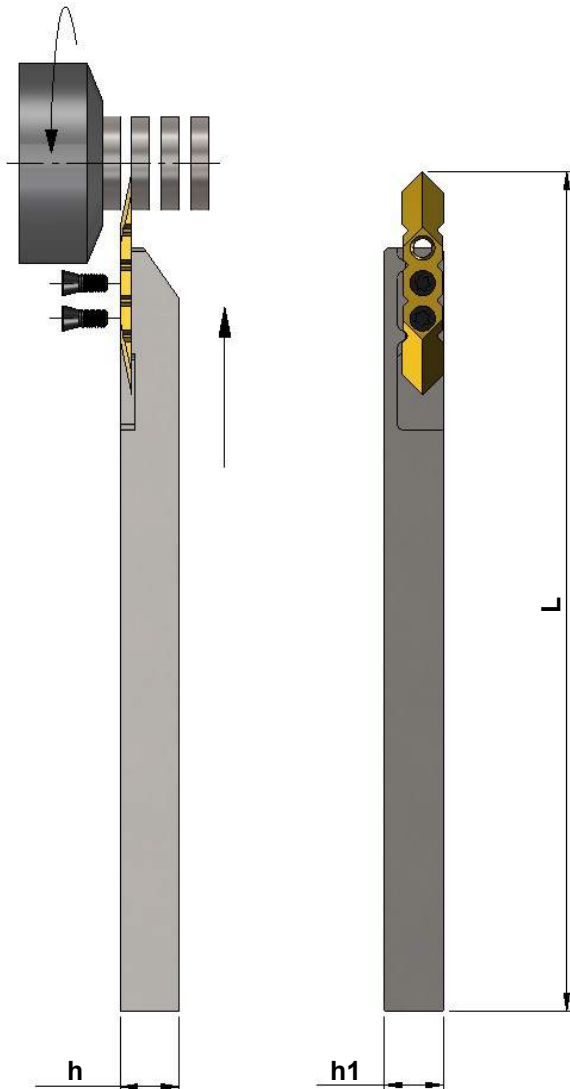

Bestellbezeichnung / Order number / No. de commande

Halter / Holder / Porte-outils	h	h1	L
KH-2-1010-L/R	10	10	140
KH-2-1212-L/R	12	12	140
KH-2-1616-L/R	16	16	125
KH-2-2020-L/R	20	20	125

Schlüssel/Key/Clef

Schraube/Screw/Vis



T8

S 3080-30°- KP

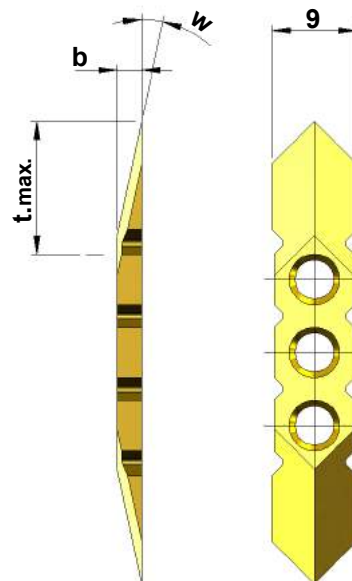

Rechtsausführung gezeichnet
Right-hand version shown
Exécution représentée à droite

Bestellbezeichnung / Order number / No. de commande

L(R)	HM-Wendeplatten Carbide inserts /Plaquettes réversibles	Unbeschichtet	b	t _{max}	w
O	KP-2-9-12°-12-18-B	UFK-2	2,0	18	12°

O = Ab Lager
Ex stock
En magasin

Abstechen von flexiblen Kunststoffen

Cut off from flexible plastics

Trancher des plastiques flexibles

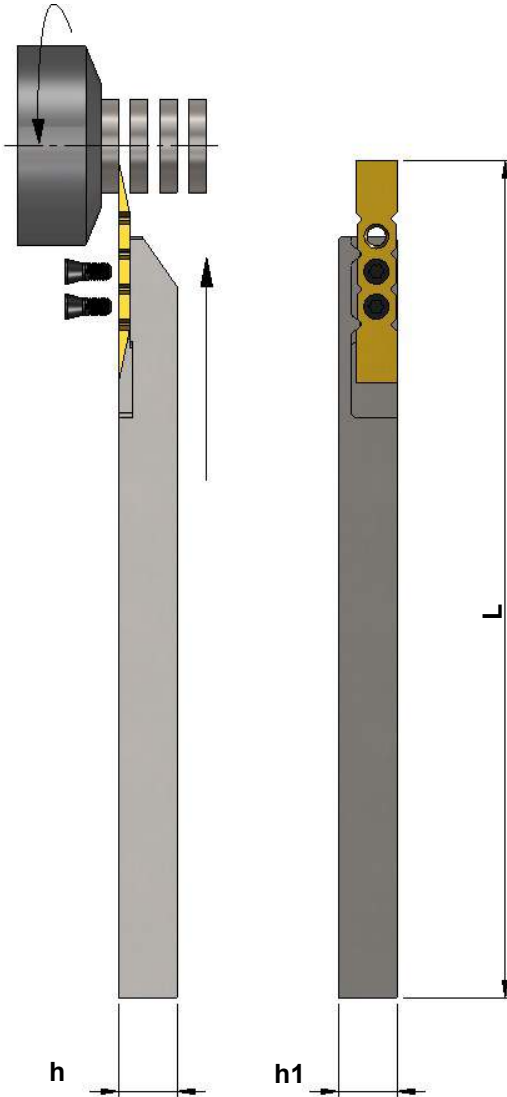

Bestellbezeichnung / Order number / No. de commande

Halter / Holder / Porte-outils	h	h1	L
KH-2-7-0808-L/R	8	8	140
KH-2-7-1010-L/R	10	10	140
KH-2-7-1212-L/R	12	12	140
KH-2-7-1616-L/R	16	16	125

Schlüssel/Key/Clef

Schraube/Screw/Vis



T8

S 3080-30°- KP

Rechtsausführung gezeichnet
Right-hand version shown
Exécution représentée à droite

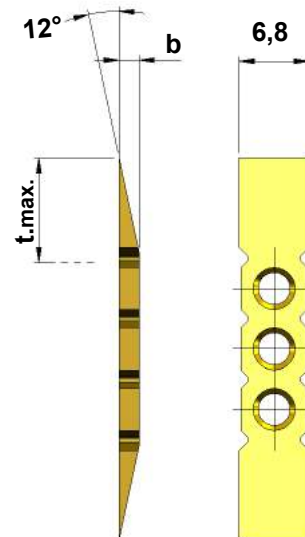

Bestellbezeichnung / Order number / No. de commande

L(R)	HM-Wendeplatten Carbide inserts /Plaquettes réversibles	Unbeschichtet	b	t _{max}
O	KP-2-7-12°-VG-10-A	UFK-2	2,0	10

O = Ab Lager
Ex stock
En magasin

Abstechen von flexiblen Kunststoffen Cut off from flexible plastics Trancher des plastiques flexibles

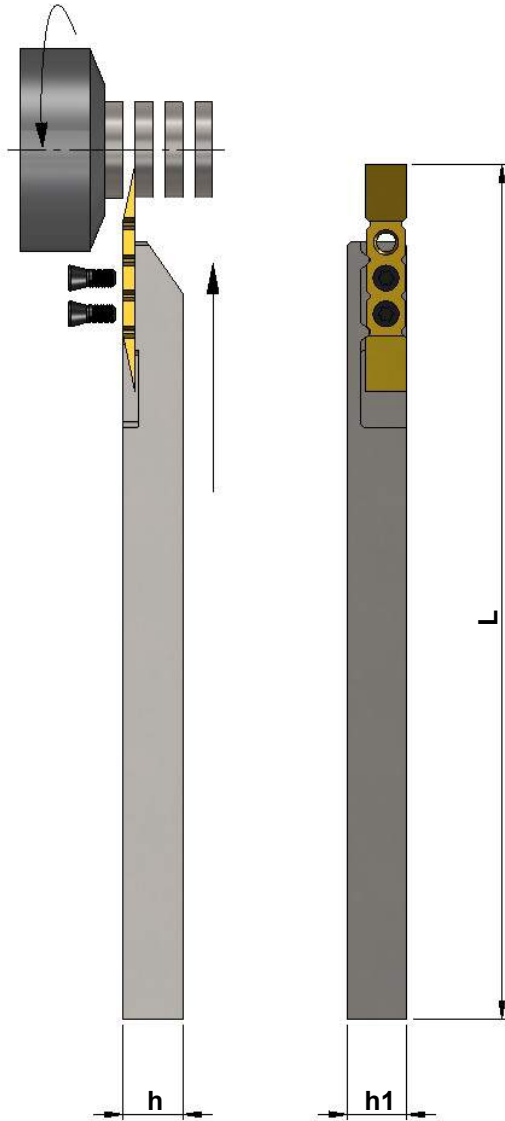

Bestellbezeichnung / Order number / No. de commande

Halter / Holder / Porte-outils	h	h1	L
KH-2-7-0808-L/R	8	8	140
KH-2-7-1010-L/R	10	10	140
KH-2-7-1212-L/R	12	12	140
KH-2-7-1616-L/R	16	16	125

Schlüssel/Key/Clef

Schraube/Screw/Vis



T8

S 3080-30°- KP

Rechtsausführung gezeichnet
Right-hand version shown
Exécution représentée à droite

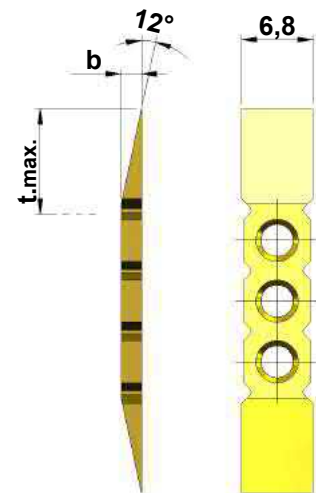

Bestellbezeichnung / Order number / No. de commande

L(R)	HM-Wendeplatten Carbide inserts /Plaquettes réversibles	Unbeschichtet	b	t _{max}
O	KP-2-7-12°-VG-10-B	UFK-2	2,0	10

Ab Lager
O = Ex stock
En magasin

Abstechen von flexiblen Kunststoffen

Cut off from flexible plastics

Trancher des plastiques flexibles

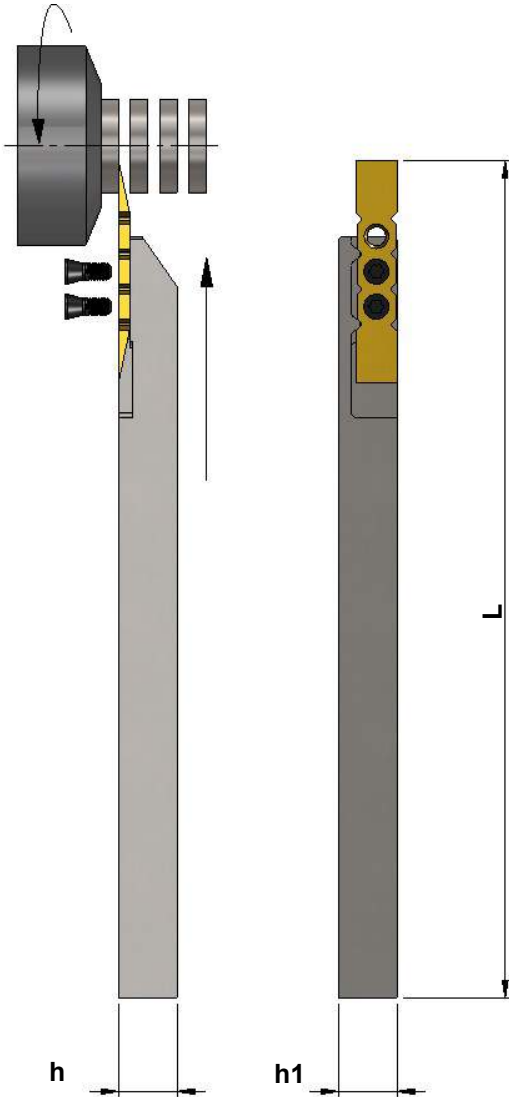

Bestellbezeichnung / Order number / No. de commande

Halter / Holder / Porte-outils	h	h1	L
KH-2-1010-L/R	10	10	140
KH-2-1212-L/R	12	12	140
KH-2-1616-L/R	16	16	125
KH-2-2020-L/R	20	20	125

Schlüssel/Key/Clef

Schraube/Screw/Vis



T8

S 3080-30°- KP

Rechtsausführung gezeichnet
Right-hand version shown
Exécution représentée à droite

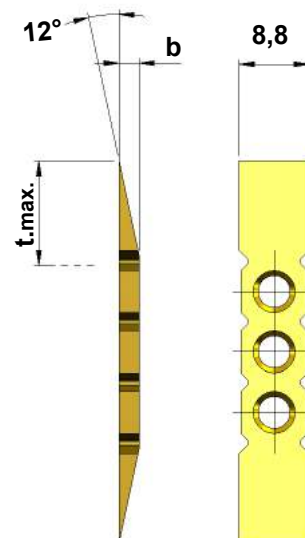

Bestellbezeichnung / Order number / No. de commande

L(R)	HM-Wendepplatten Carbide inserts /Plaquettes réversibles	Unbeschichtet	b	t _{max}
O	KP-2-9-12°-VG-12-18-A	UFK-2	2,0	18

Ab Lager
O = Ex stock
En magasin

Abstechen von flexiblen Kunststoffen

Cut off from flexible plastics

Trancher des plastiques flexibles

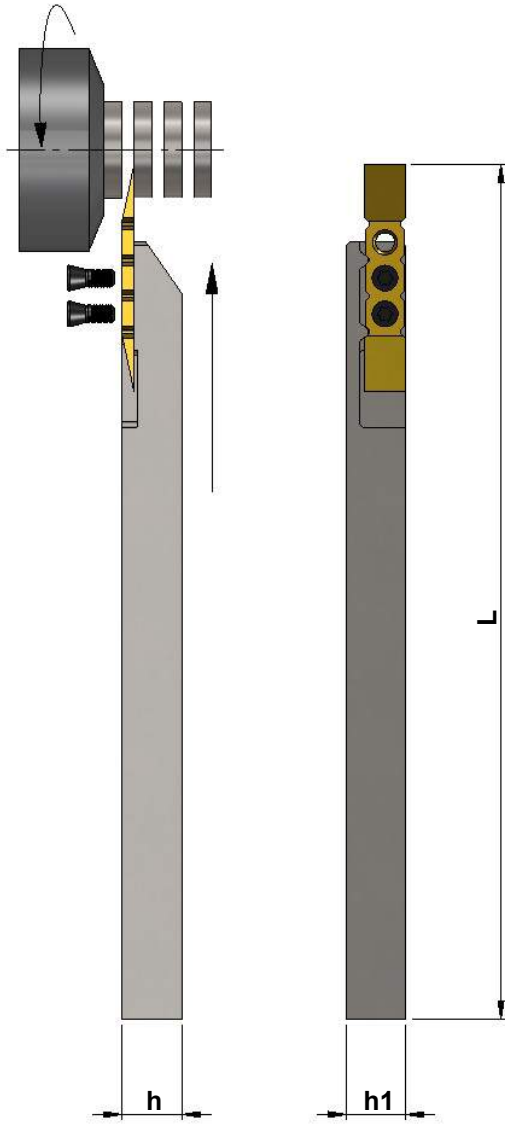

Bestellbezeichnung / Order number / No. de commande

Halter / Holder / Porte-outils	h	h1	L
KH-2-1010-L/R	10	10	140
KH-2-1212-L/R	12	12	140
KH-2-1616-L/R	16	16	125
KH-2-2020-L/R	20	20	125

Schlüssel/Key/Clef

Schraube/Screw/Vis



T8

S 3080-30°- KP

Rechtsausführung gezeichnet
Right-hand version shown
Exécution représentée à droite

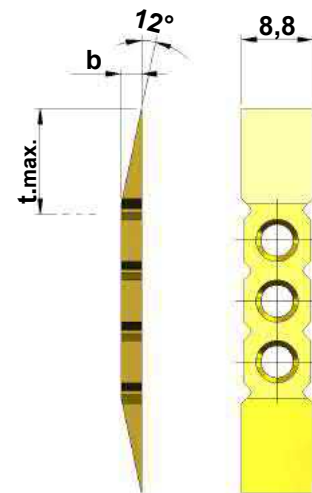

Bestellbezeichnung / Order number / No. de commande

L(R)	HM-Wendepplatten Carbide inserts / Plaquettes réversibles	Unbeschichtet	b	t _{max}
O	KP-2-9-12°-VG-12-18-B	UFK-2	2,0	18

Ab Lager
O = Ex stock
En magasin

Kopierdrehen

Copying tools / Outils de decolletage

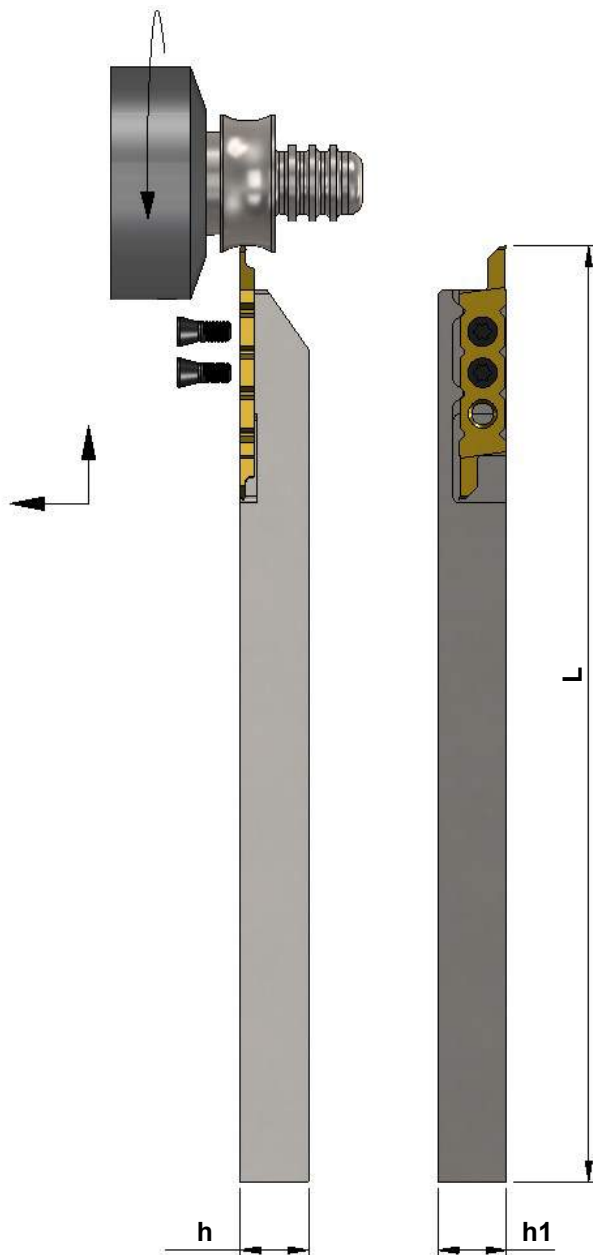
Bestellbezeichnung / Order number / No. de commande

Halter / Holder / Porte-outils	h	h1	L
KH-2-7-0808-L/R	8	8	140
KH-2-7-1010-L/R	10	10	140
KH-2-7-1212-L/R	12	12	140
KH-2-7-1616-L/R	16	16	125

Schlüssel/Key/Clef

Schraube/Screw/Vis



T8

S 3080-30°- KP

Rechter Halter rechte Platte
 Right-hand holder right-hand insert
 Porte-outil droite Plaquette droite

Linker Halter linke Platte
 Left-hand holder left-hand insert
 Porte-outil gauche Plaquette gauche

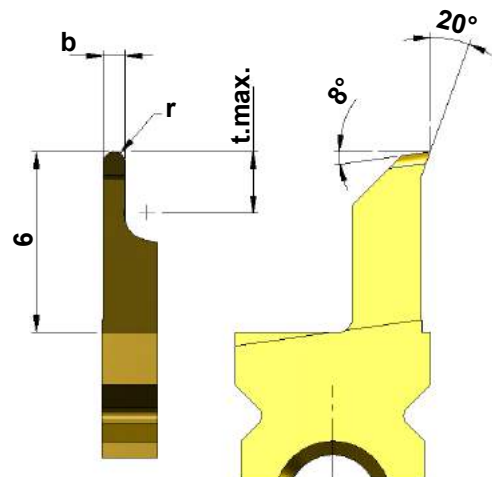
Rechtsausführung gezeichnet

Right-hand version shown / Exécution représentée à droite

Bestellbezeichnung / Order number / No. de commande

L	R	HM-Wendeplatten Carbide inserts Plaquettes réversibles	Unbeschichtet Uncoated Non-revêtu	b	tmax.	r.
O	O	KP-2-7-04-R02-6-L/R	UFK-2	0.4	2.2	0.2
O	O	KP-2-7-08-R04-6-L/R	UFK-2	0.8	4.0	0.4

O = Ab Lager
 Ex stock
 En magasin

Kopierdrehen Copying tools / Outils de decolletage

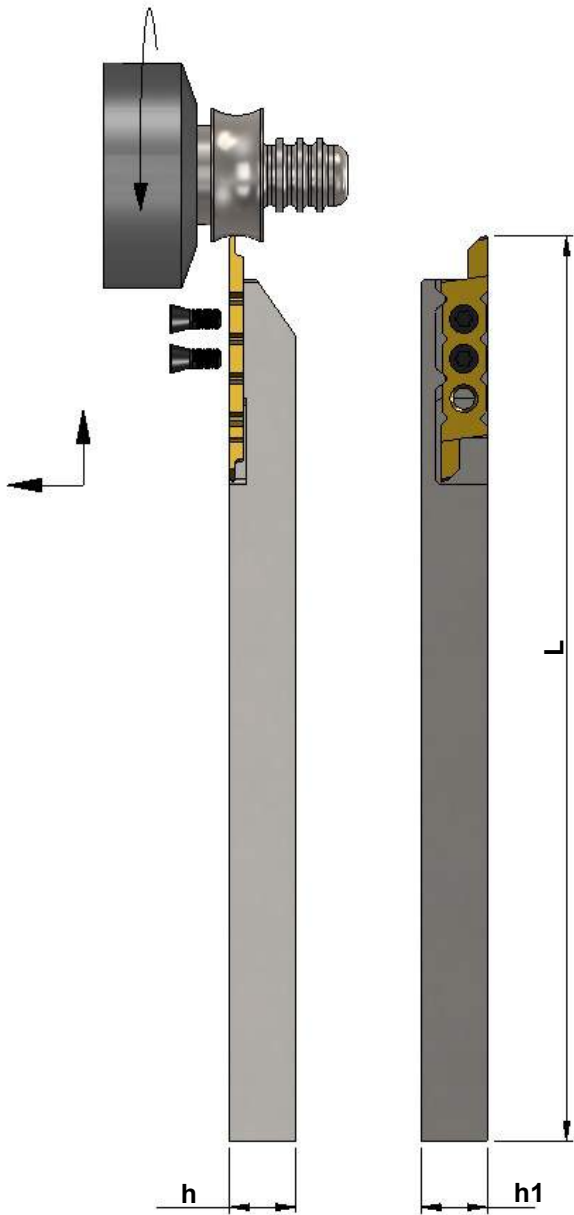

Bestellbezeichnung / Order number / No. de commande

Halter / Holder / Porte-outils	h	h1	L
KH-2-7-0808-L/R	8	8	140
KH-2-7-1010-L/R	10	10	140
KH-2-7-1212-L/R	12	12	140
KH-2-7-1616-L/R	16	16	125

Schlüssel/Key/Clef

Schraube/Screw/Vis



T8

S 3080-30°- KP

Rechter Halter rechte Platte
Right-hand holder right-hand insert
Porte-outil droite Plaquette droite

Linker Halter linke Platte
Left-hand holder left-hand insert
Porte-outil gauche Plaquette gauche

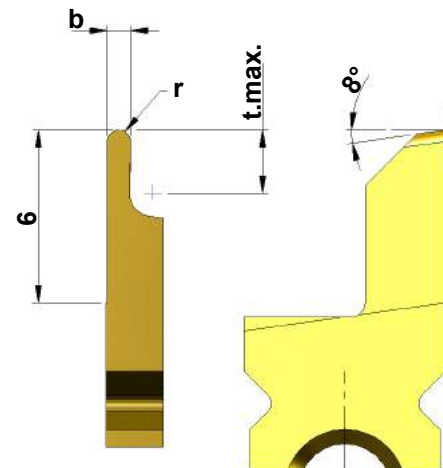

Rechtsausführung gezeichnet

Right-hand version shown / Exécution représentée à droite

Bestellbezeichnung / Order number / No. de commande

L	R	HM-Wendeplatten Carbide inserts Plaquettes réversibles	Unbeschichtet Uncoated Non-revêtu	b	tmax.	r.
O	O	KP-2-7-04-P-R02-6-L/R	UFK-2	0.4	2.2	0.2
O	O	KP-2-7-08-P-R04-6-L/R	UFK-2	0.8	4.0	0.4

O = Ab Lager
Ex stock
En magasin

Kopierdrehen

Copying tools / Outils de decolletage

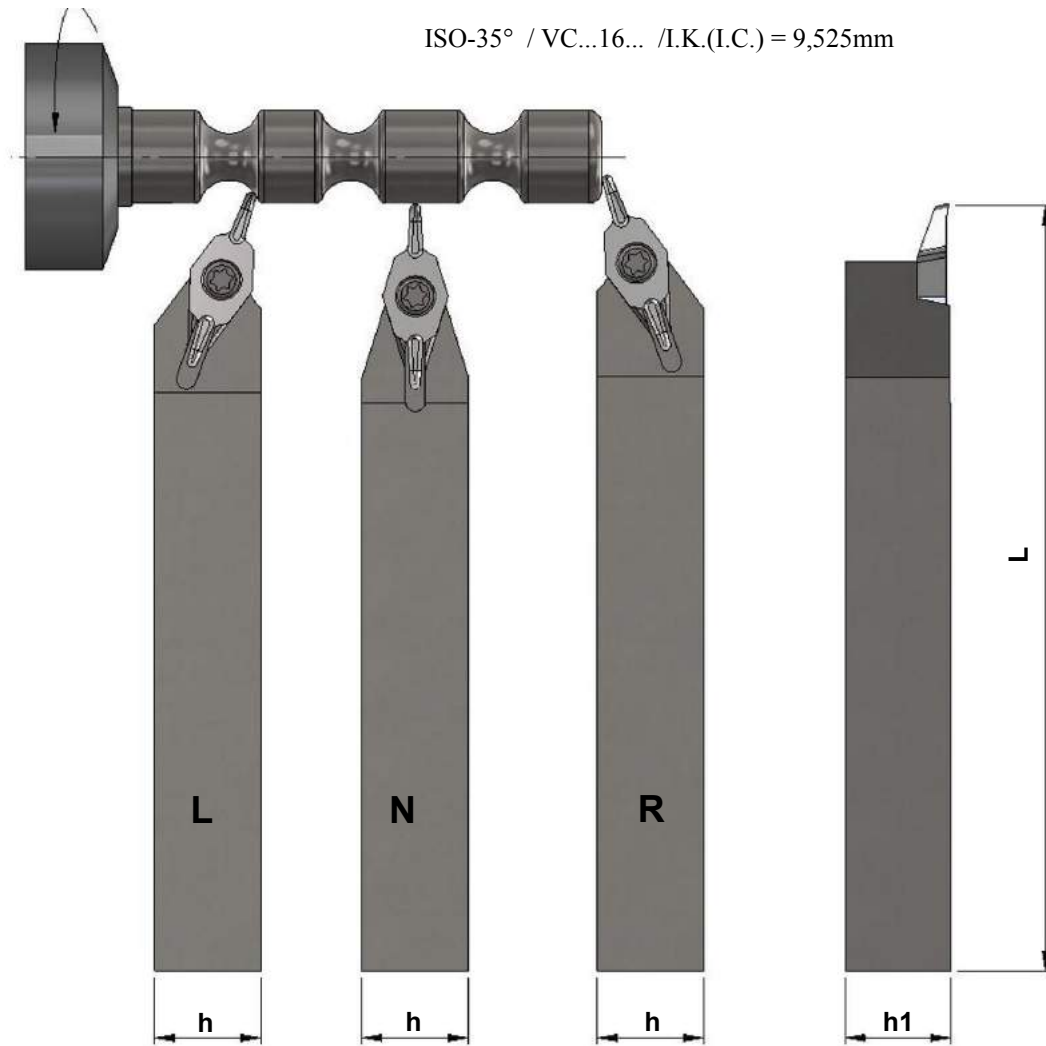

Bestellbezeichnung / Order number / No. de commande

Halter / Holder / Porte-outils	h	h1	L
SDAC-1635-1212-N-KP	12	12	140
SDAC-1635-1616-L-KP	16	16	125
SDAC-1635-1616-N-KP	16	16	125
SDAC-1635-1616-R-KP	16	16	125
SDAC-1635-2020-L-KP	20	20	125
SDAC-1635-2020-N-KP	20	20	125
SDAC-1635-2020-R-KP	20	20	125

Schlüssel/Key/Clef



Schraube/Screw/Vis



Kopierdrehen

Copying tools / Outils de décolletage

ISO-35° / VC...16... / l.K.(l.C.) = 9,525mm

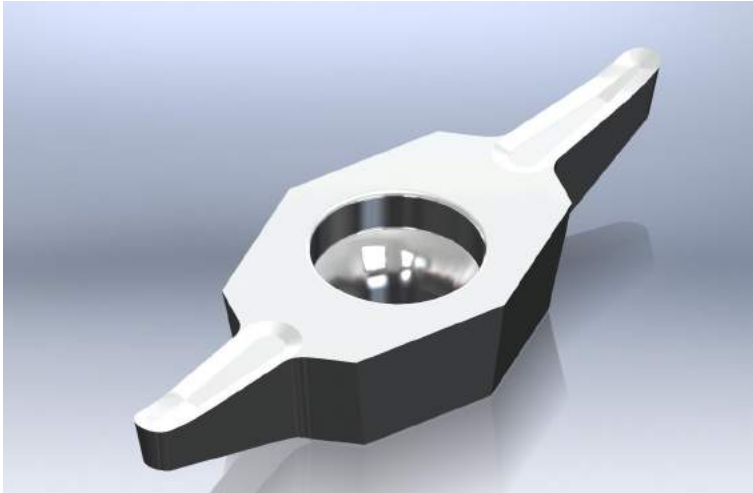

sehr scharfe Schneiden
Spanfläche poliert

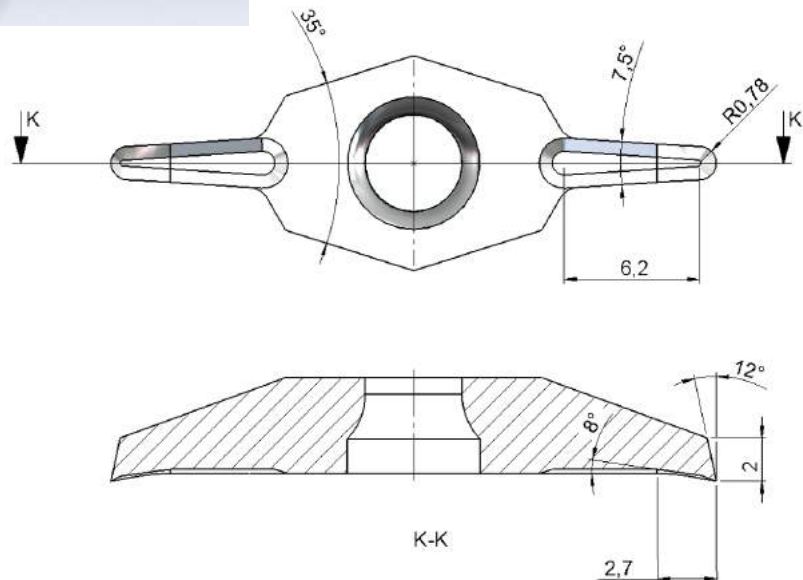

Bestellbezeichnung / Order number / No. de commande

HM-Wendepplatten Carbide inserts Plaquettes réversibles	Unbeschichtet Uncoated Non-revêtu	r
KP-VCGT-16-S	K10	0.78

Kopierdrehen

Copying tools / Outils de decolletage

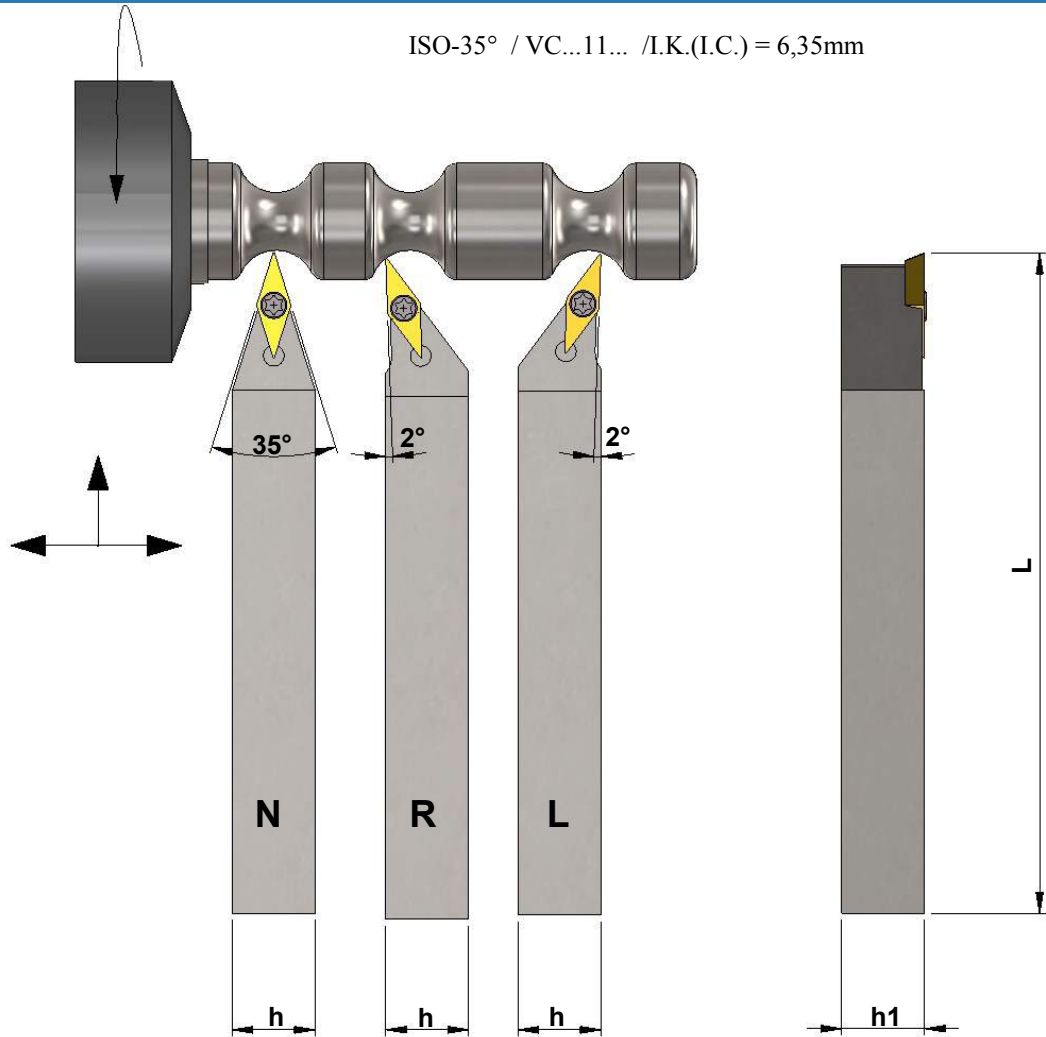

Bestellbezeichnung / Order number / No. de commande

Halter / Holder / Porte-outils	h	h1	L
SDAC-1135-0808-L	8	8	140
SDAC-1135-0808-N	8	8	140
SDAC-1135-0808-R	8	8	140
SDAC-1135-1010-L	10	10	140
SDAC-1135-1010-N	10	10	140
SDAC-1135-1010-R	10	10	140
SDAC-1135-1212-L	12	12	140
SDAC-1135-1212-N	12	12	140
SDAC-1135-1212-R	12	12	140
SDAC-1135-1616-L	16	16	125
SDAC-1135-1616-N	16	16	125
SDAC-1135-1616-R	16	16	125

Schlüssel/Key/Clef



Schraube/Screw/Vis



Kopierdrehen

Copying tools / Outils de decolletage

ISO-35° / VC...11... / I.K.(I.C.) = 6,35mm

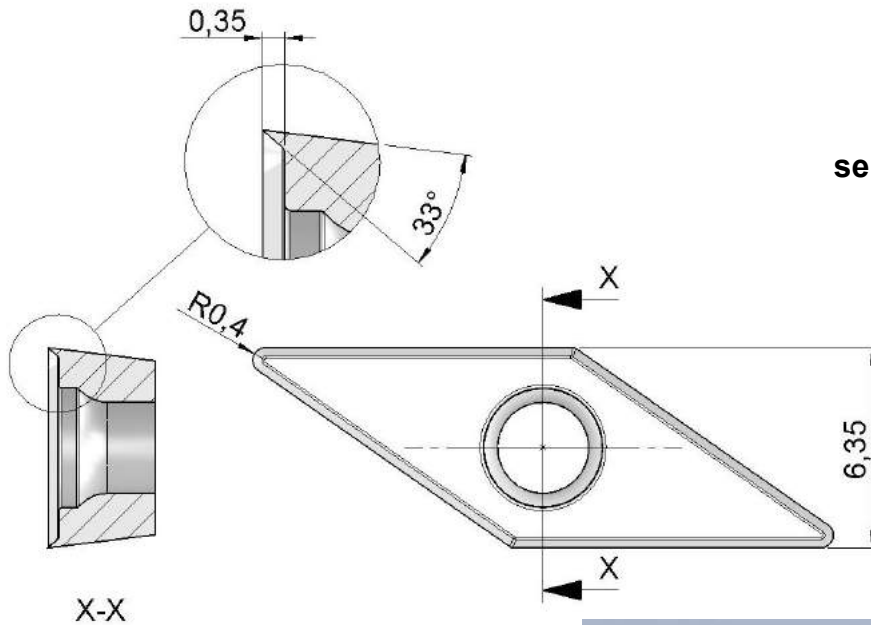

sehr scharfe Schneiden

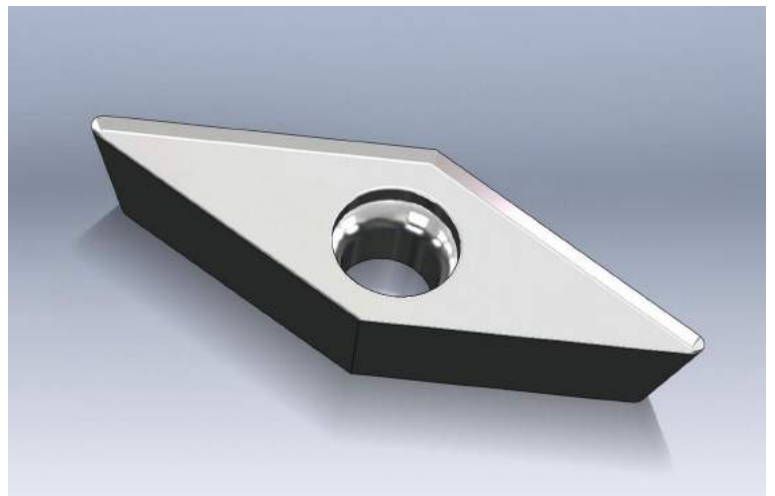

Bestellbezeichnung / Order number / No. de commande

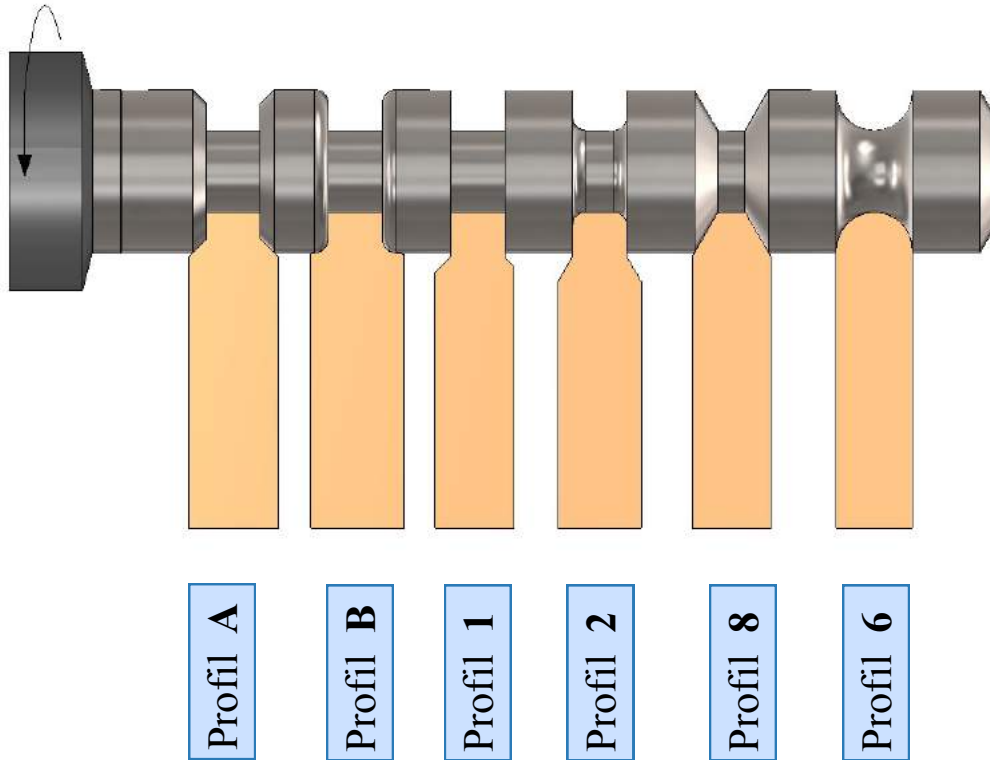

HM-Wendepplatten Carbide inserts Plaquettes réversibles	Unbeschichtet Uncoated Non-revêtu	r
KP-VCGT-11-S	K10	0.4

Bearbeitungsbeispiele mit KP-2-7.. HM-Profilplatten
 Machining examples with profiled KP-2-7.. carbide inserts
 Exemples d'usinage avec plaquettes de profil en carbure monobloc KP-2-7..



Bestellbezeichnung /Order number /No. de commande

Halter / Holder / Porte-outils	h	h1	L
KH-2-7-1010-L/R	10	10	140
KH-2-7-1212-L/R	12	12	140
KH-2-7-1616-L/R	16	16	125

Schlüssel/Key/Clef  T8	Schraube/Screw/Vis  S 3080-30°- KP
---	--

Rechter Halter rechte Platte
 Right-hand holder right-hand insert
 Porte-outil droite Plaquette droite

Linker Halter linke Platte
 Left-hand holder left-hand insert
 Porte-outil gauche Plaquette gauche

Bearbeitungsbeispiele mit KP-2-7.. HM-Profilplatten
 Machining examples with profiled KP-2-7.. carbide inserts
 Exemples d'usinage avec plaquettes de profil en carbure monobloc KP-2-7..

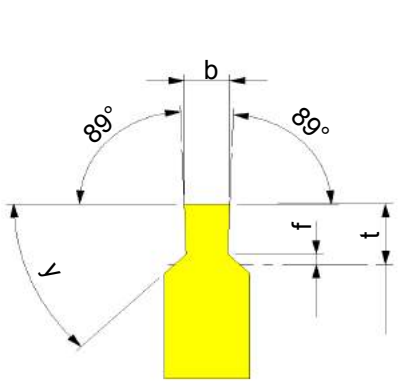

Profil A

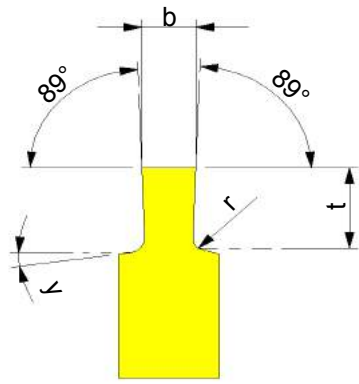

Profil B

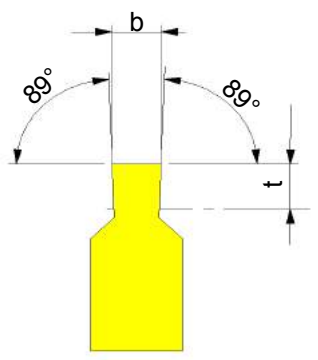

Profil 1

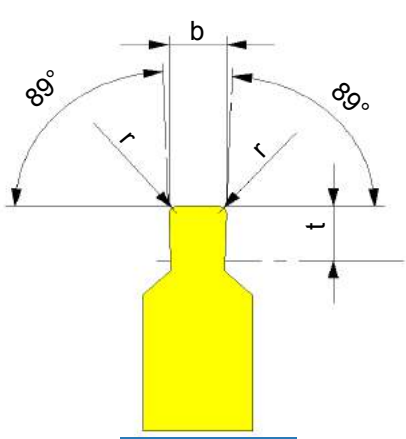

Profil 2

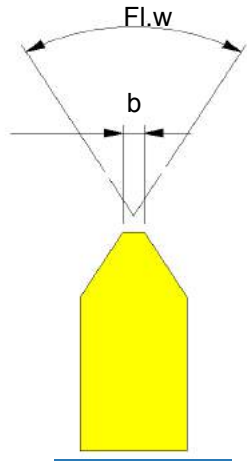

Profil 8

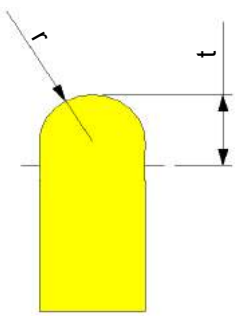
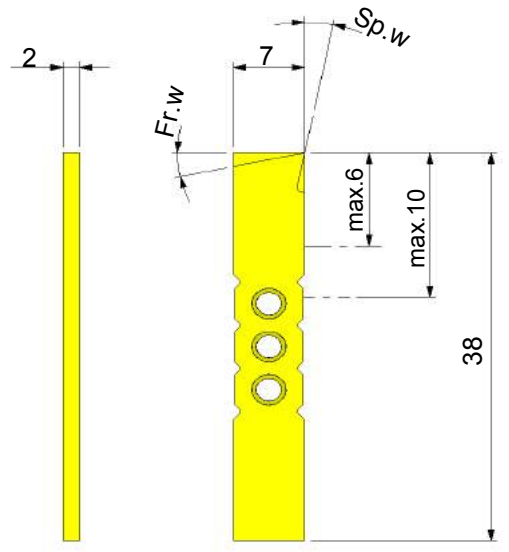

Profil 6

Unbeschichtet Uncoated Non-révélu	PKD PCD
UFK-2	

Bestellsystem KP-2-7.. / Ordering-system KP-2-7.. / Système de commande KP-2-7..

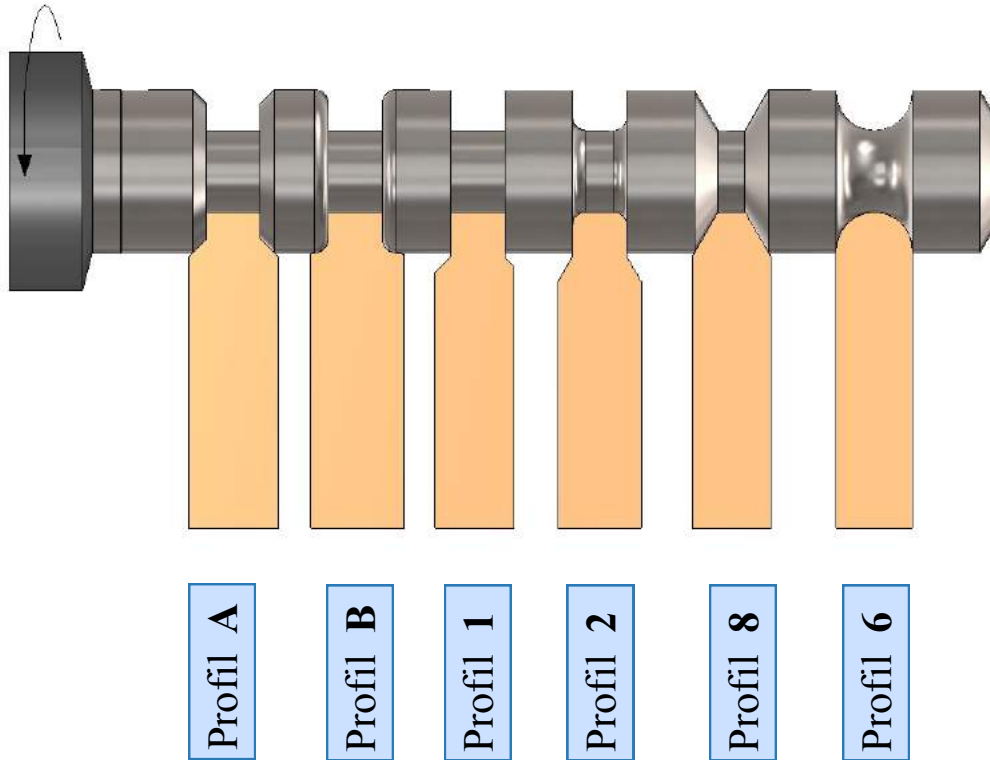

Bestellsystem KP-2-7.. Ordering-system KP-2-7.. Système de commande KP-2-7	Profil	b	t	f	y	r	Fl.w	Sp.w	Fr.w
KP-2-7-UFK2-RO									

Bearbeitungsbeispiele mit KP-2-9.. HM-Profilplatten
 Machining examples with profiled KP-2-9.. carbide inserts
 Exemples d'usinage avec plaquettes de profil en carbure monobloc KP-2-9..



Bestellbezeichnung /Order number /No. de commande

Halter / Holder / Porte-outils	h	h1	L
KH-2-1212-L/R	12	12	140
KH-2-1616-L/R	16	16	125
KH-2-2020-L/R	20	20	125

Schlüssel/Key/Clef	Schraube/Screw/Vis
	
T8	S 3080-30°- KP

Rechter Halter rechte Platte
 Right-hand holder right-hand insert
 Porte-outil droite Plaquette droite

Linker Halter linke Platte
 Left-hand holder left-hand insert
 Porte-outil gauche Plaquette gauche

Bearbeitungsbeispiele mit KP-2-9.. HM-Profilplatten
 Machining examples with profiled KP-2-9.. carbide inserts
 Exemples d'usinage avec plaquettes de profil en carbure monobloc KP-2-9..

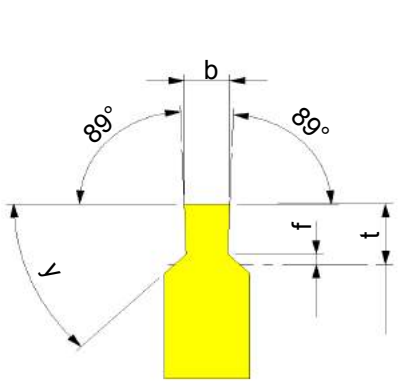

Profil A

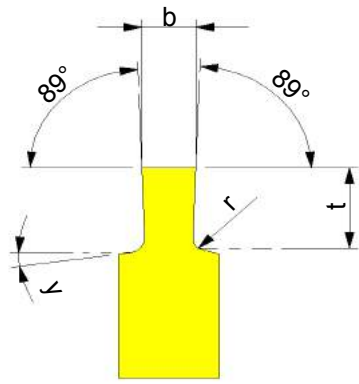

Profil B

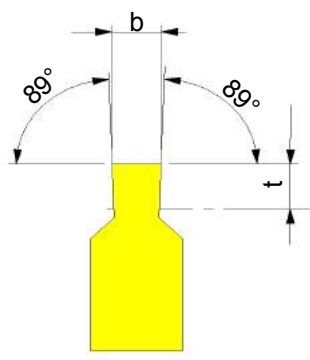

Profil 1

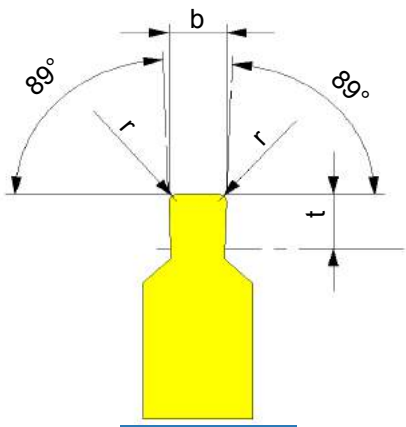

Profil 2

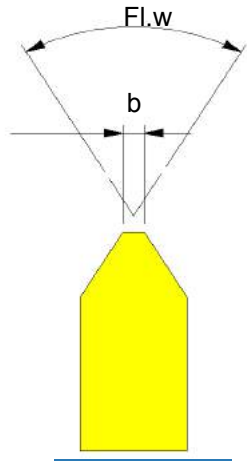

Profil 8

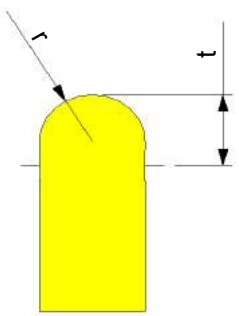
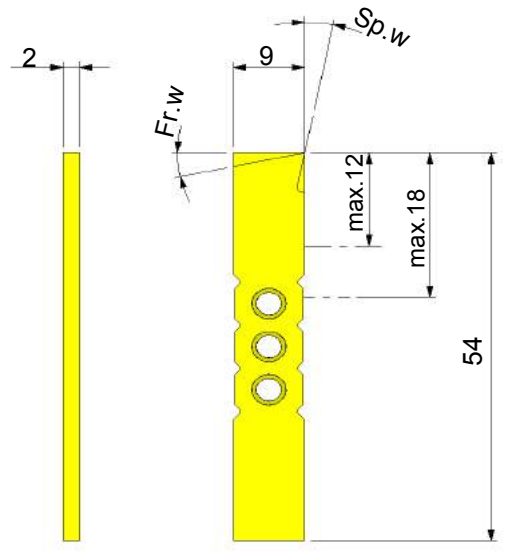

Profil 6

Unbeschichtet Uncoated Non-révélu	PKD PCD
UFK-2	

Bestellsystem KP-2-9.. / Ordering-system KP-2-9.. / Système de commande KP-2-9..

Bestellsystem KP-2-9.. Ordering-system KP-2-9.. Système de commande KP-2-9	Profil	b	t	f	y	r	Fl.w	Sp.w	Fr.w
KP-2-9-UFK2-RO									

Kopierdrehen

Copying tools / Outils de decolletage

ISO-35° / VC...07... / I.K.(I.C.) = 3,97mm

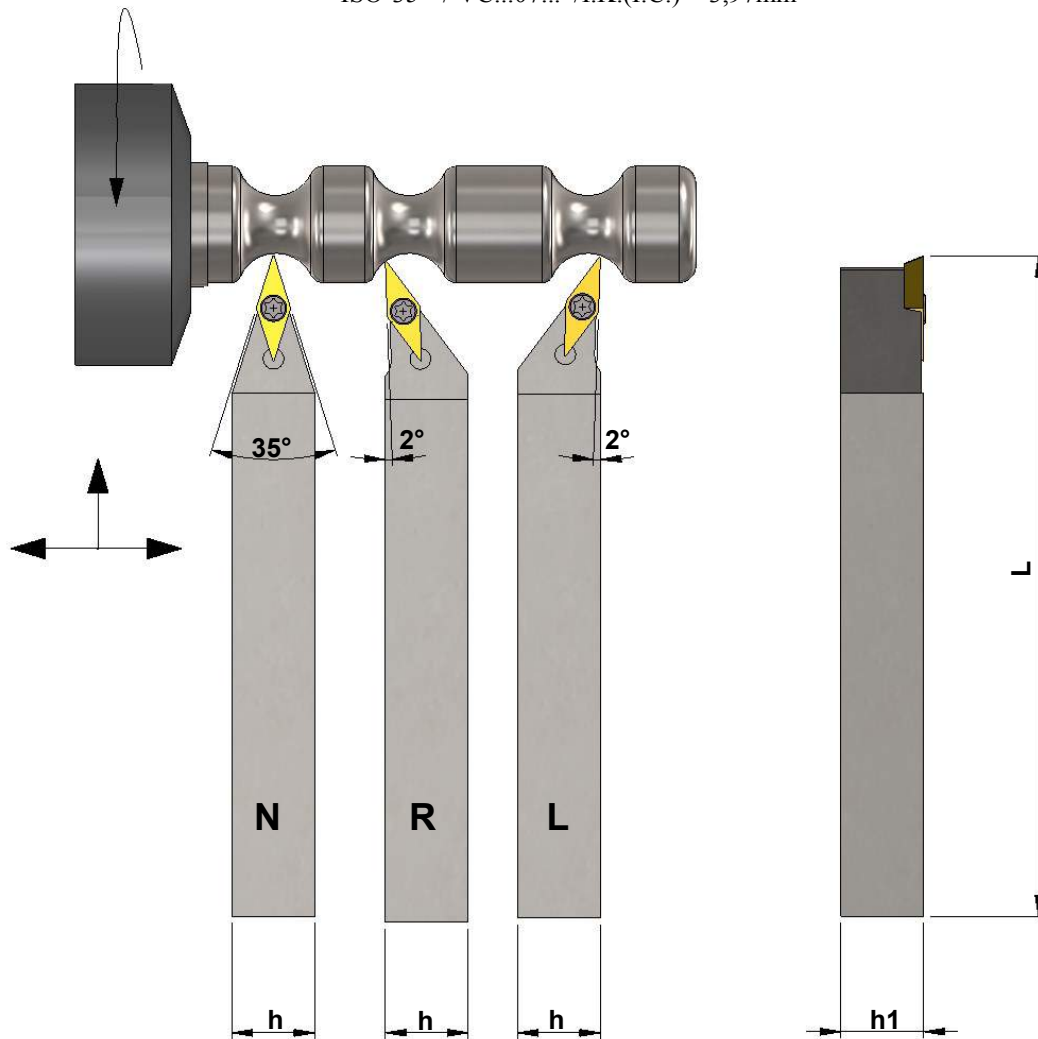

Bestellbezeichnung / Order number / No. de commande

Halter / Holder / Porte-outils	h	h1	L
SDAC-0735-0808-L	8	8	140
SDAC-0735-0808-N	8	8	140
SDAC-0735-0808-R	8	8	140
SDAC-0735-1010-L	10	10	140
SDAC-0735-1010-N	10	10	140
SDAC-0735-1010-R	10	10	140
SDAC-0735-1212-L	12	12	140
SDAC-0735-1212-R	12	12	140

Schlüssel/Key/Clef



T6

Schraube/Screw/Vis



M2050

Kopierdrehen

Copying tools / Outils de decolletage

ISO-35° / VC...07... / l.K.(l.C.) = 3,97mm

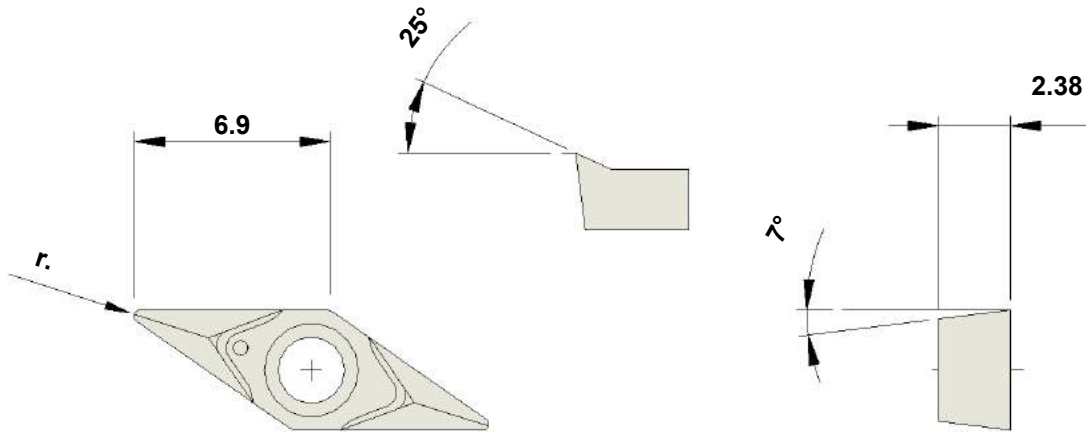

Bestellbezeichnung / Order number / No. de commande

HM-Wendepplatten Carbide inserts Plaquettes réversibles	Unbeschichtet Uncoated Non-revêtu	r.
VCGT-070202-N-FS-G7B	K10	0.2

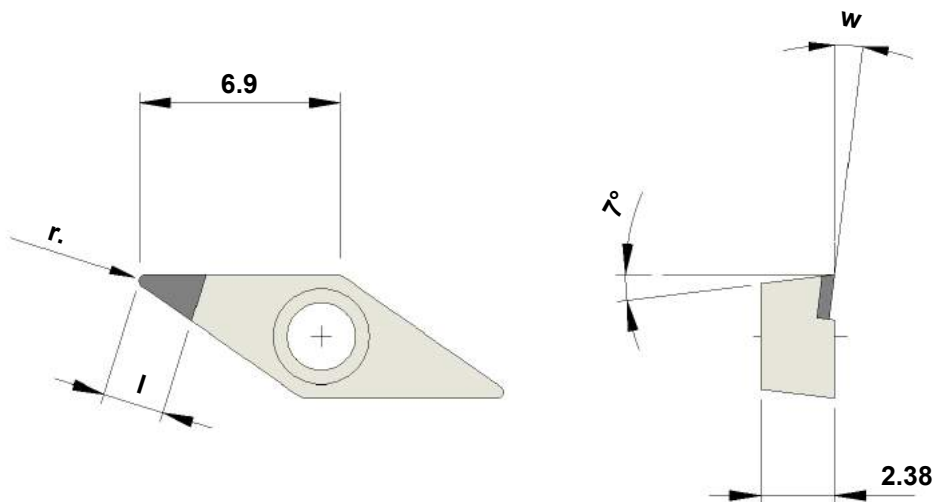

Bestellbezeichnung / Order number / No. de commande

PKD-Schneidplatten PCD- inserts Plaquettes PCD	l	r	w
VCMW-070201-FN-PKD	3.8	0.1	0°
VCMW-070202-FN-PKD	3.6	0.2	0°
VCMT-070201-FN-PKD	3.8	0.1	7°
VCMT-070202-FN-PKD	3.6	0.2	7°

Kopierdrehen

Copying tools / Outils de decolletage

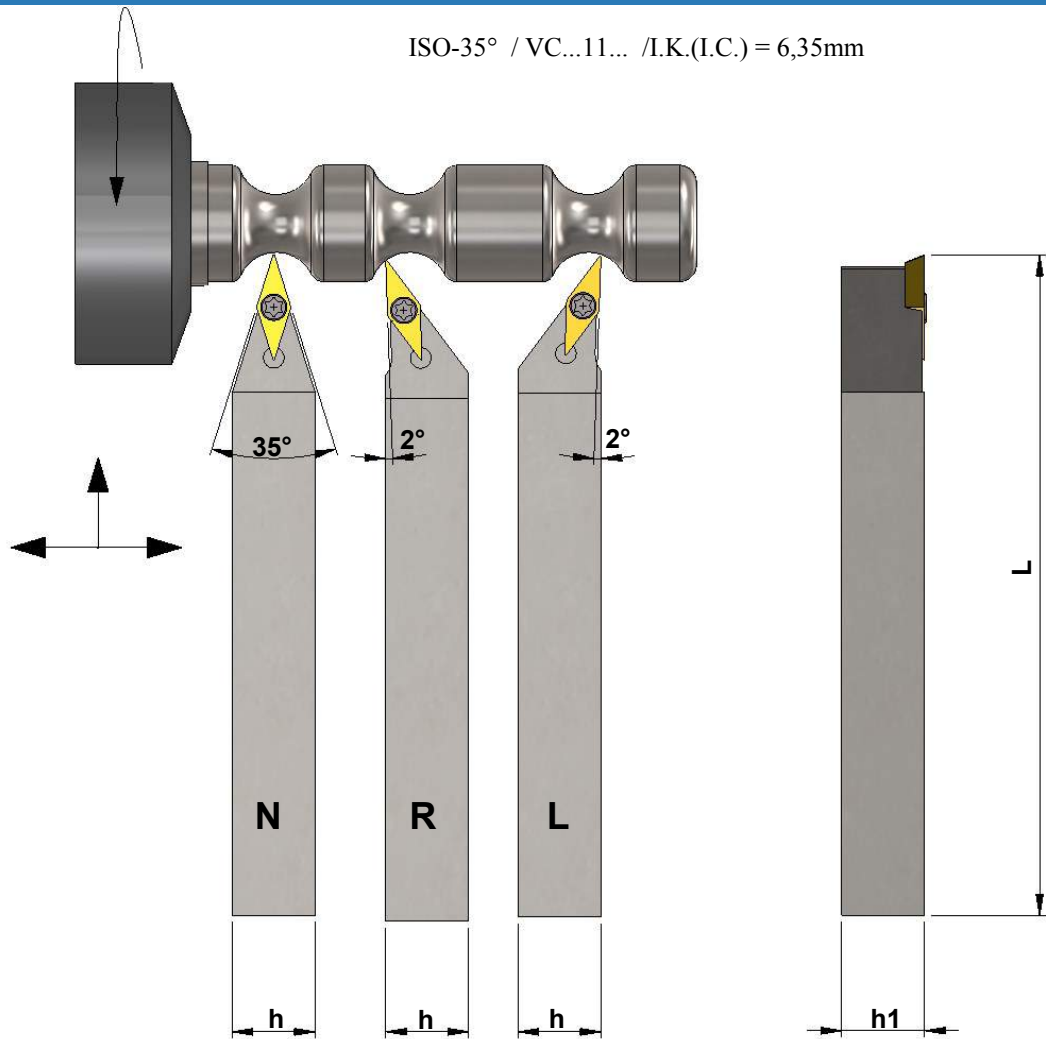

Bestellbezeichnung / Order number / No. de commande

Halter / Holder / Porte-outils	h	h1	L
SDAC-1135-0808-L	8	8	140
SDAC-1135-0808-N	8	8	140
SDAC-1135-0808-R	8	8	140
SDAC-1135-1010-L	10	10	140
SDAC-1135-1010-N	10	10	140
SDAC-1135-1010-R	10	10	140
SDAC-1135-1212-L	12	12	140
SDAC-1135-1212-N	12	12	140
SDAC-1135-1212-R	12	12	140
SDAC-1135-1616-L	16	16	125
SDAC-1135-1616-N	16	16	125
SDAC-1135-1616-R	16	16	125

Schlüssel/Key/Clef



Schraube/Screw/Vis



Kopierdrehen

Copying tools / Outils de decolletage

ISO-35° / VC...11... / l.K.(l.C.) = 6,35mm

Bestellbezeichnung / Order number / No. de commande

HM-Wendepplatten Carbide inserts Plaquettes réversibles	Unbeschichtet Uncoated Non-revêtu	r
VCGW-110301-N-FA-G6A	K10	0.1
VCGW-110302-N-FA-G6A	K10	0.2
VCGW-110304-N-FA-G6A	K10	0.4

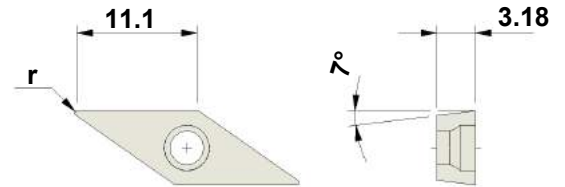

HM-Wendepplatten Carbide inserts Plaquettes réversibles	Unbeschichtet Uncoated Non-revêtu	r
VCGT-1103005-N-ASF-G7B	K10	0.05
VCGT-110301-N-ASF-G7B	K10	0.1
VCGT-110302-N-ASF-G7B	K10	0.2
VCGT-110304-N-ASF-G7B	K10	0.4

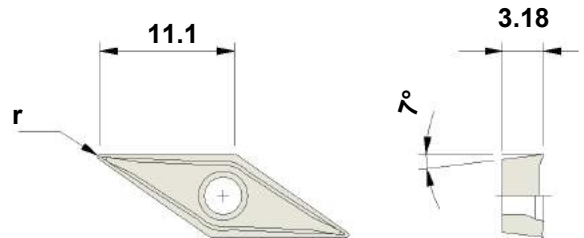

HM-Wendepplatten Carbide inserts Plaquettes réversibles	Unbeschichtet Uncoated Non-revêtu	r
VCGT-110301-N-Alu-FA-G7B	K10	0.1
VCGT-110302-N-Alu-FA-G7B	K10	0.2
VCGT-110304-N-Alu-FA-G7B	K10	0.4
VCGT-110308-N-Alu-FA-G7B	K10	0.8

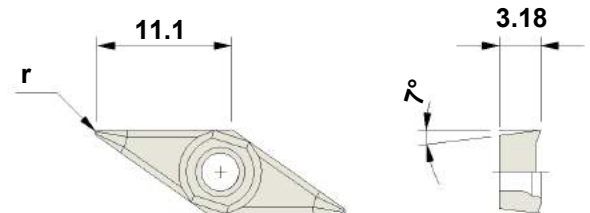

HM-Wendepplatten Carbide inserts Plaquettes réversibles	Unbeschichtet Uncoated Non-revêtu	r
VCGT-110302-N-Alu-FB-G7B	K10	0.2
VCGT-110304-N-Alu-FB-G7B	K10	0.4

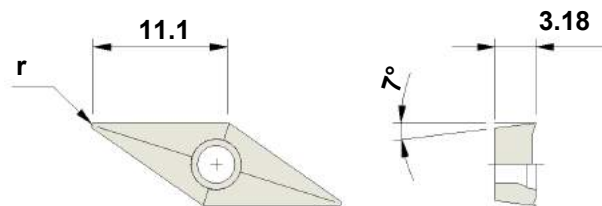

PKD-Schneidplatten PCD- inserts Plaquettes PCD	l	r	w
VCMW-110302-FN-PKD	4.6	0.2	0°
VCMW-110304-FN-PKD	3.9	0.4	0°
VCMT-110302-FN-PKD	4.6	0.2	7°
VCMT-110304-FN-PKD	3.9	0.4	7°

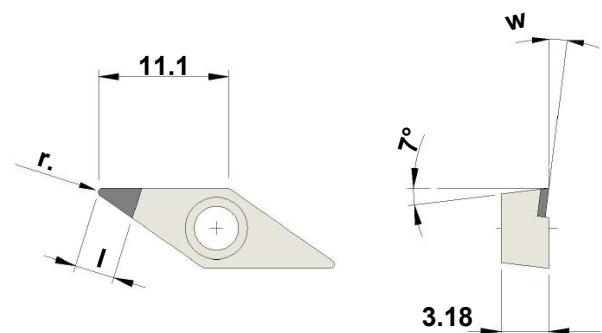

Kopierdrehen Copying tools / Outils de decolletage

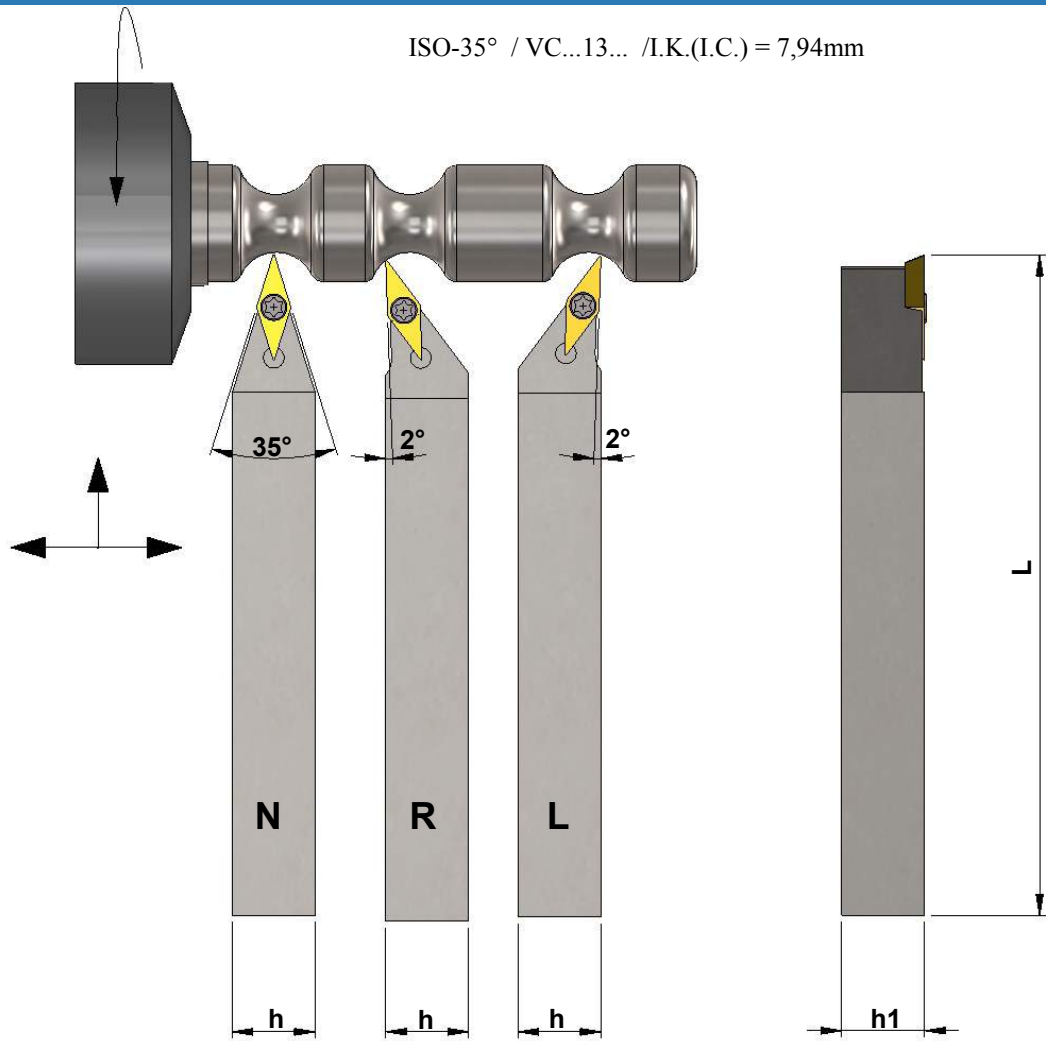

Bestellbezeichnung / Order number / No. de commande

Halter / Holder / Porte-outils	h	h1	L
SDAC-1335-1010-N	10	10	140
SDAC-1335-1212-L	12	12	140
SDAC-1335-1212-N	12	12	140
SDAC-1335-1212-R	12	12	140
SDAC-1335-1616-L	16	16	125
SDAC-1335-1616-N	16	16	125
SDAC-1335-1616-R	16	16	125
SDAC-1335-2020-L	20	20	125
SDAC-1335-2020-N	20	20	125
SDAC-1335-2020-R	20	20	125

Schlüssel/Key/Clef



T9

Schraube/Screw/Vis



M3x7.2

Kopierdrehen

Copying tools / Outils de decolletage

ISO-35° / VC...13... / l.K.(l.C.) = 7,94mm

Bestellbezeichnung / Order number / No. de commande

HM-Wendepplatten Carbide inserts Plaquettes réversibles	Unbeschichtet Uncoated Non-revêtu	r
VCGW-130301-N-FA-G6A	K10	0.1
VCGW-130302-N-FS-G6A	K10	0.2
VCGW-130304-N-FS-G6A	K10	0.4

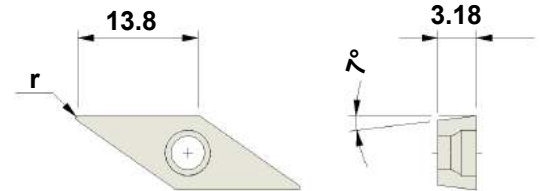

HM-Wendepplatten Carbide inserts Plaquettes réversibles	Unbeschichtet Uncoated Non-revêtu	r
VCGT-130302-N-Alu-FS-G7B	K10	0.2
VCGT-130304-N-Alu-FS-G7B	K10	0.4
VCGT-130308-N-Alu-FS-G7B	K10	0.8

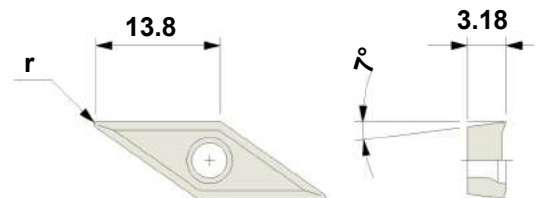

HM-Wendepplatten Carbide inserts Plaquettes réversibles	Unbeschichtet Uncoated Non-revêtu	r
VCGT-130304-N-ASF-FA	K10	0.4

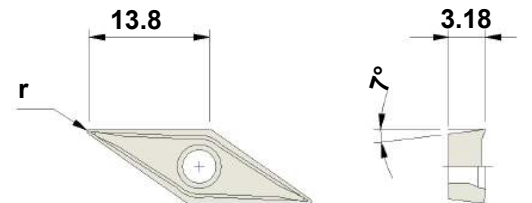

HM-Wendepplatten Carbide inserts Plaquettes réversibles	Unbeschichtet Uncoated Non-revêtu	r
VCGT-130301-N-Alu-FA-G7B	K10	0.1
VCGT-130302-N-Alu-FA-G7B	K10	0.2
VCGT-130304-N-Alu-FA-G7B	K10	0.4

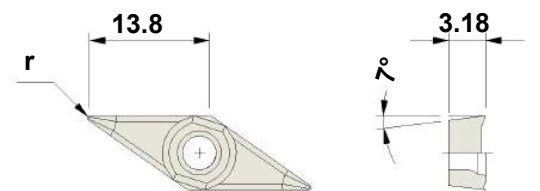

HM-Wendepplatten Carbide inserts Plaquettes réversibles	Unbeschichtet Uncoated Non-revêtu	r
VCGT-130304-N-FA-ACB	K10	0.4

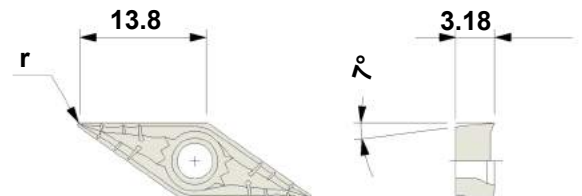

PKD-Schneidplatten PCD- inserts Plaquettes PCD	l	r	w
VCMW-130302-FN-PKD	5.9	0.2	0°
VCMW-130304-FN-PKD	5.5	0.4	0°
VCMT-130302-FN-PKD	5.9	0.2	7°

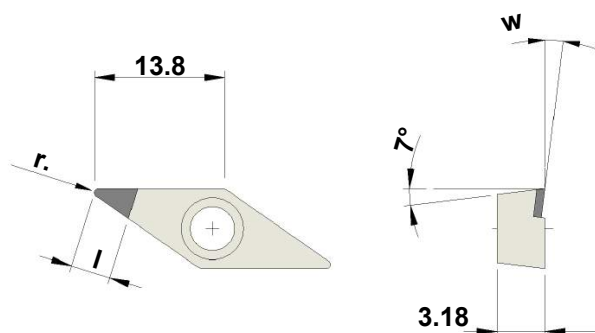

Kopierdrehen Copying tools / Outils de decolletage

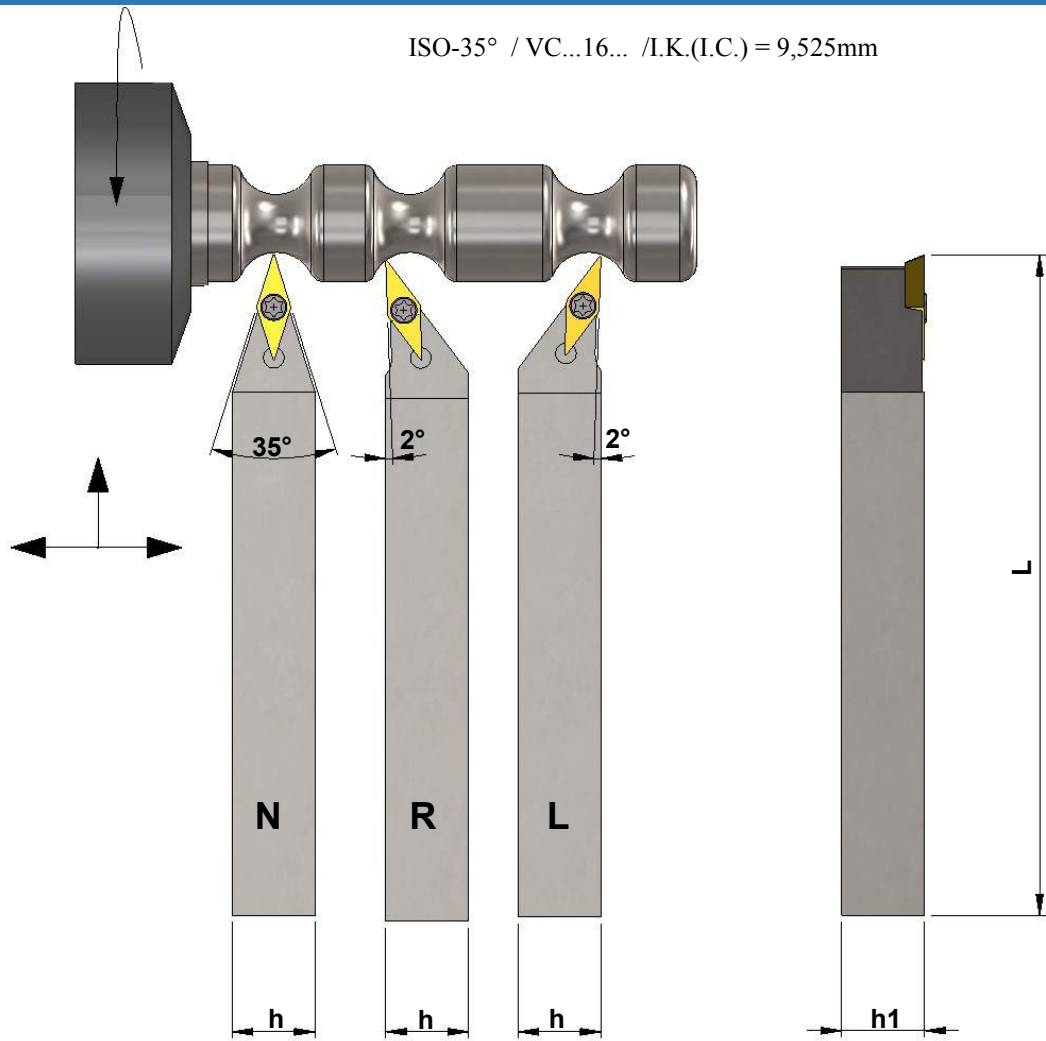

Bestellbezeichnung / Order number / No. de commande			
Halter / Holder / Porte-outils	h	h1	L
SDAC-1635-1212-N	12	12	140
SDAC-1635-1616-L	16	16	125
SDAC-1635-1616-N	16	16	125
SDAC-1635-1616-R	16	16	125
SDAC-1635-2020-L	20	20	125
SDAC-1635-2020-N	20	20	125
SDAC-1635-2020-R	20	20	125

Schlüssel/Key/Clef



T15

Schraube/Screw/Vis



M4x9.5

Kopierdrehen

Copying tools / Outils de decolletage

ISO-35° / VC...16... / I.K.(I.C.) = 9,525mm

Bestellbezeichnung / Order number / No. de commande

HM-Wendepplatten Carbide inserts Plaquettes réversibles	Unbeschichtet Uncoated Non-revêtu	r
VCGT-160404-N-Alu-FA-G7B	K10	0.4
VCGT-160408-N-Alu-FA-G7B	K10	0.8

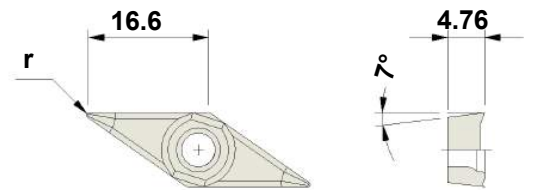

HM-Wendepplatten Carbide inserts Plaquettes réversibles	Unbeschichtet Uncoated Non-revêtu	r
VCGT-160402-N-Alu-FB-G7B	K10	0.2
VCGT-160404-N-Alu-FB-G7B	K10	0.4
VCGT-160408-N-Alu-FB-G7B	K10	0.8

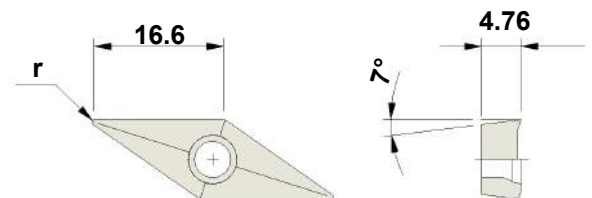

PKD-Schneidplatten PCD- inserts Plaquettes PCD	l	r	w
VCMW-160402-FN-PKD	5.9	0.2	0°
VCMW-160404-FN-PKD	5.5	0.4	0°
VCMT-160402-FN-PKD	5.9	0.2	7°
VCMT-160404-FN-PKD	5.5	0.4	7°

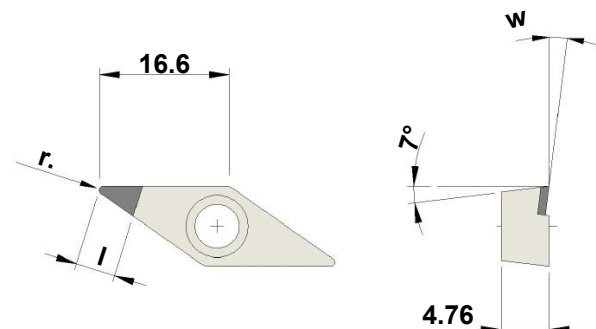

Kopierdrehen Copying tools / Outils de decolletage

ISO-35° / VC...11... / I.K.(I.C.) = 6,35mm

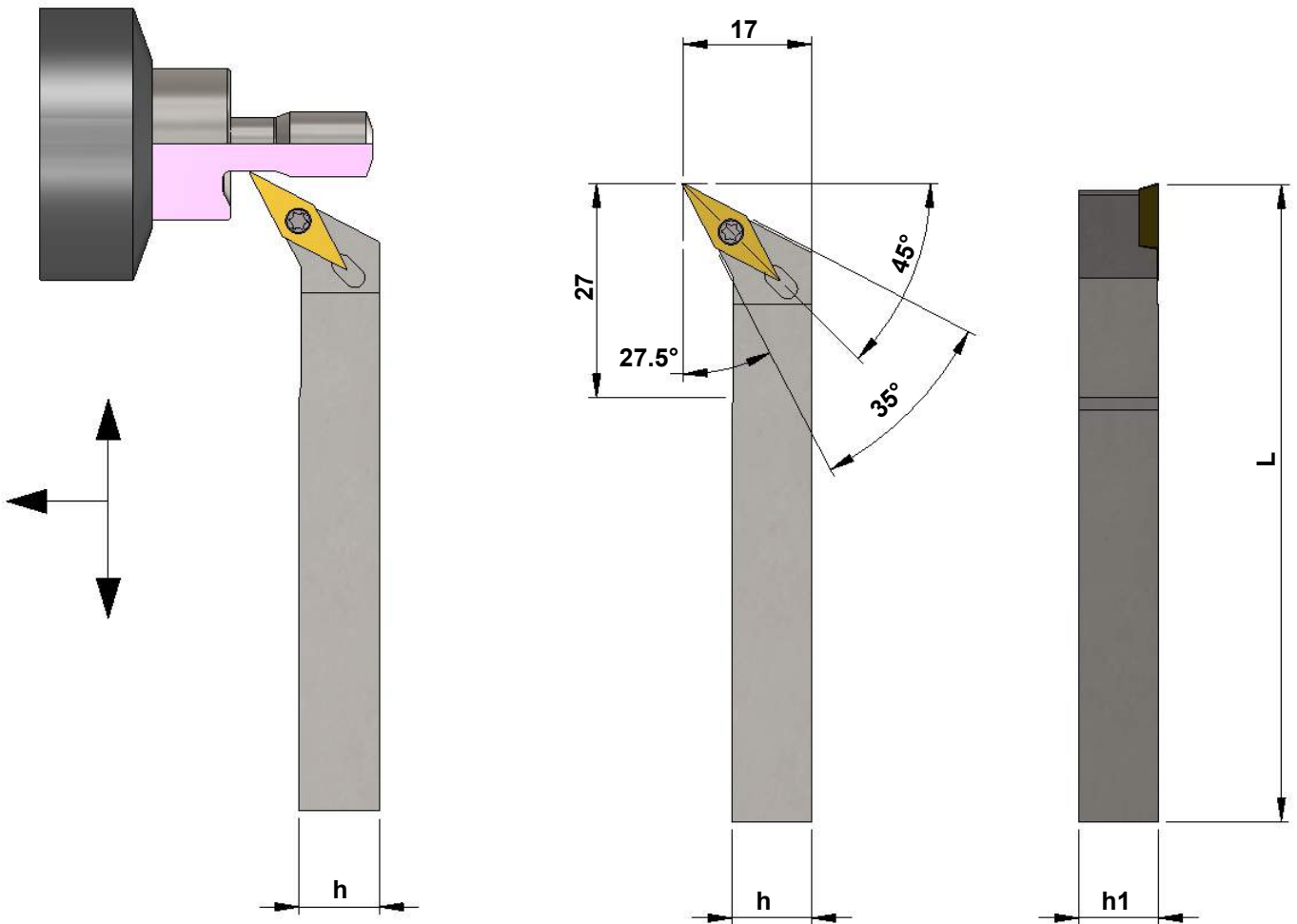

Bestellbezeichnung / Order number / No. de commande

Halter / Holder / Porte-outils	h	h1	L
SDAC-275-1135-1010-L/R	10	10	140
SDAC-275-1135-1212-L/R	12	12	125
SDAC-275-1135-1616-L/R	16	16	125

Schlüssel/Key/Clef



T7

Schraube/Screw/Vis



M2.5x7

Kopierdrehen

Copying tools / Outils de decolletage

ISO-35° / VC...11... / l.K.(l.C.) = 6,35mm

Bestellbezeichnung / Order number / No. de commande

HM-Wendepplatten Carbide inserts Plaquettes réversibles	Unbeschichtet Uncoated Non-revêtu	r
VCGW-110301-N-FA-G6A	K10	0.1
VCGW-110302-N-FA-G6A	K10	0.2
VCGW-110304-N-FA-G6A	K10	0.4

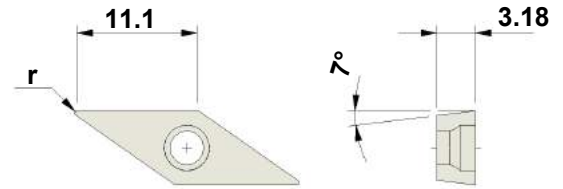

HM-Wendepplatten Carbide inserts Plaquettes réversibles	Unbeschichtet Uncoated Non-revêtu	r
VCGT-1103005-N-ASF-G7B	K10	0.05
VCGT-110301-N-ASF-G7B	K10	0.1
VCGT-110302-N-ASF-G7B	K10	0.2
VCGT-110304-N-ASF-G7B	K10	0.4

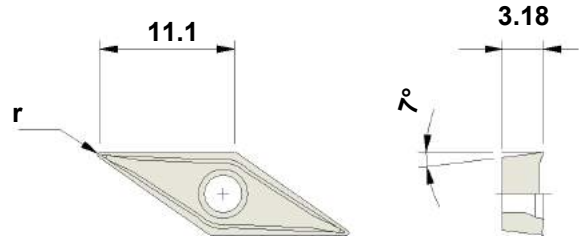

HM-Wendepplatten Carbide inserts Plaquettes réversibles	Unbeschichtet Uncoated Non-revêtu	r
VCGT-110301-N-Alu-FA-G7B	K10	0.1
VCGT-110302-N-Alu-FA-G7B	K10	0.2
VCGT-110304-N-Alu-FA-G7B	K10	0.4
VCGT-110308-N-Alu-FA-G7B	K10	0.8

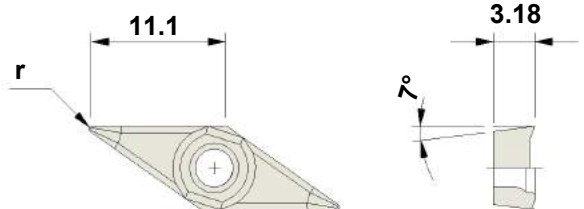

HM-Wendepplatten Carbide inserts Plaquettes réversibles	Unbeschichtet Uncoated Non-revêtu	r
VCGT-110302-N-Alu-FB-G7B	K10	0.2
VCGT-110304-N-Alu-FB-G7B	K10	0.4

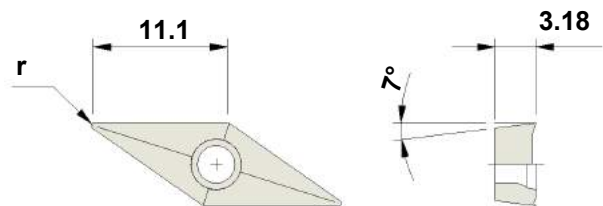

PKD-Schneidplatten PCD- inserts Plaquettes PCD	l	r	w
VCMW-110302-FN-PKD	4.6	0.2	0°
VCMW-110304-FN-PKD	3.9	0.4	0°
VCMT-110302-FN-PKD	4.6	0.2	7°
VCMT-110304-FN-PKD	3.9	0.4	7°

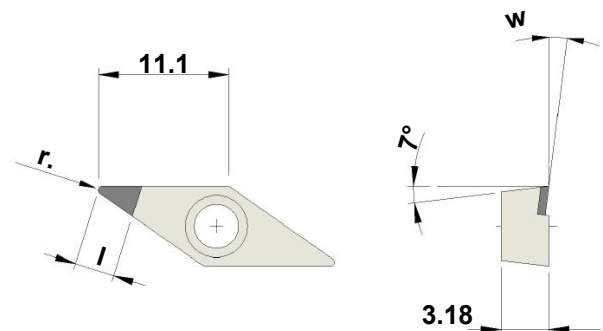

Kopierdrehen Copying tools / Outils de decolletage

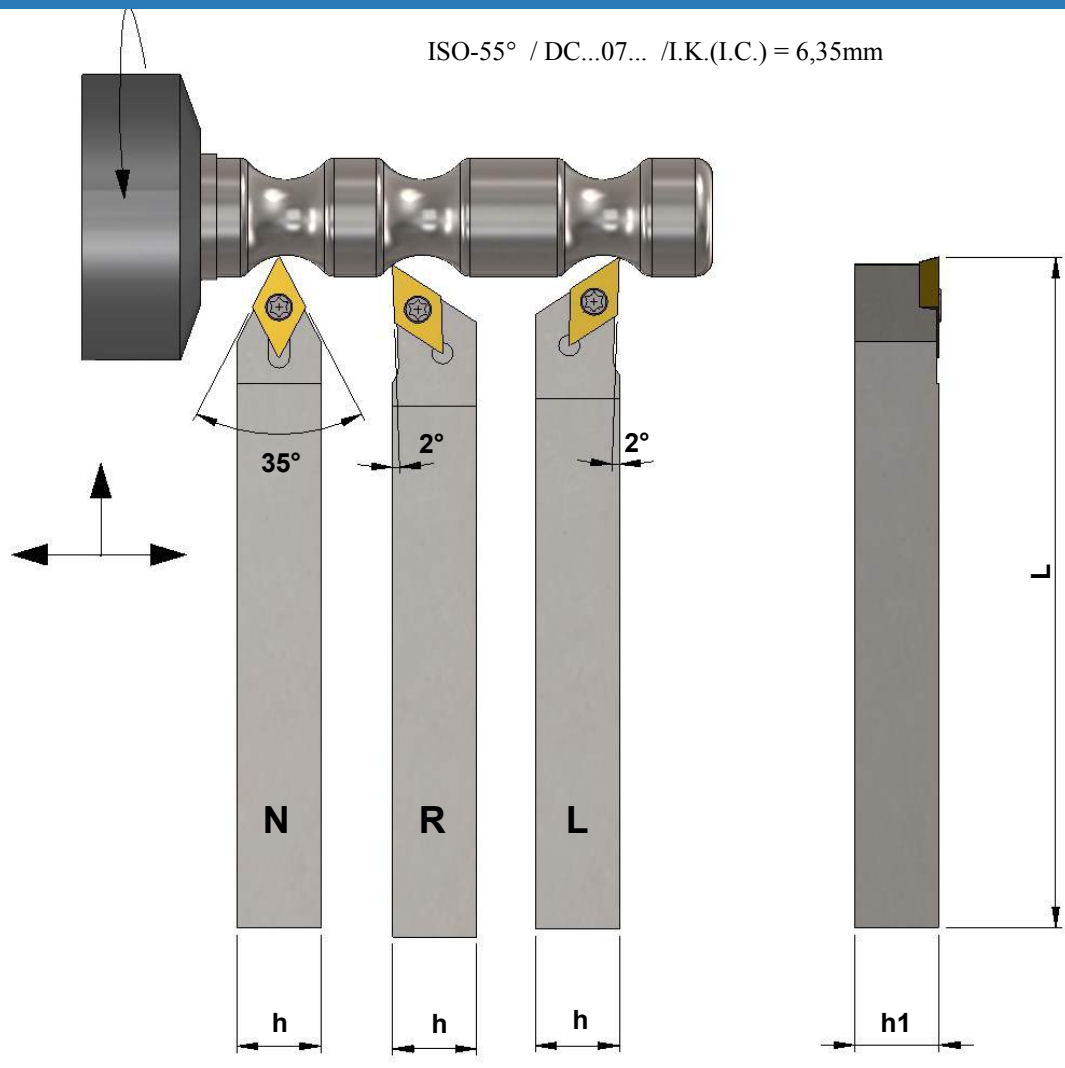

Bestellbezeichnung / Order number / No. de commande

Halter / Holder / Porte-outils	h	h1	L
SDAC-0755-0808-L	8	8	140
SDAC-0755-0808-N	8	8	140
SDAC-0755-0808-R	8	8	140
SDAC-0755-1010-L	10	10	140
SDAC-0755-1010-N	10	10	140
SDAC-0755-1010-R	10	10	140
SDAC-0755-1212-L	12	12	140
SDAC-0755-1212-N	12	12	140
SDAC-0755-1212-L	12	12	140

Schlüssel/Key/Clef



T7

Schraube/Screw/Vis



M2.5x7

Kopierdrehen

Copying tools / Outils de decolletage

ISO-55° / DC...07... / l.K.(l.C.) = 6,35mm

Bestellbezeichnung / Order number / No. de commande

HM-Wendeplatten Carbide inserts Plaquettes réversibles	Unbeschichtet Uncoated Non-revêtu	r
DCGW-070202-N-G6A	K10	0.2
DCGW-070204-N-G6A	K10	0.4

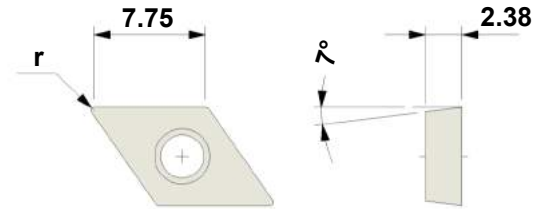

HM-Wendeplatten Carbide inserts Plaquettes réversibles	Unbeschichtet Uncoated Non-revêtu	r
DCGT-0702005-N-ASF-G7B	K10	0.05
DCGT-070202-N-ASF-G7B	K10	0.2
DCGT-070204-N-ASF-G7B	K10	0.4

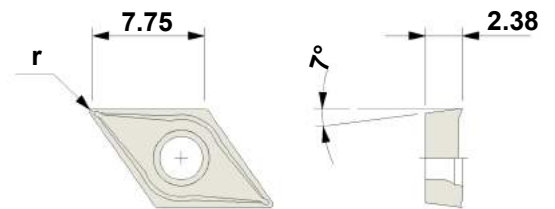

HM-Wendeplatten Carbide inserts Plaquettes réversibles	Unbeschichtet Uncoated Non-revêtu	r
DCGT-070202-N-Alu-FA-G7B	K10	0.2
DCGT-070204-N-Alu-FA-G7B	K10	0.4

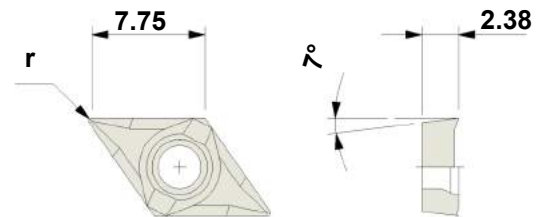

HM-Wendeplatten Carbide inserts Plaquettes réversibles	Unbeschichtet Uncoated Non-revêtu	r
DCGT-070202-N-Alu-FB-G7B	K10	0.2
DCGT-070204-N-Alu-FB-G7B	K10	0.4

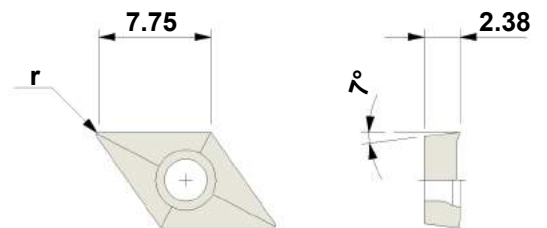

PKD-Schneidplatten PCD- inserts Plaquettes PCD	l	r	w
DCMT-070202-FN-PKD	3.0	0.2	7°
DCMT-070204-FN-PKD	3.4	0.4	7°

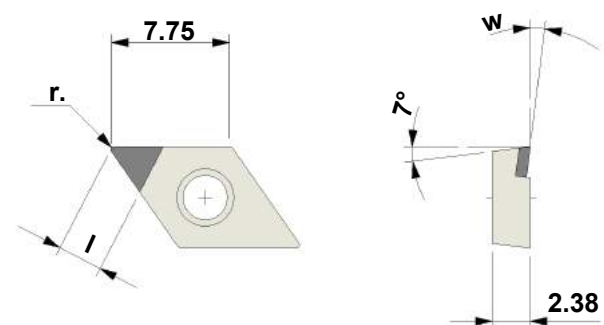

Kopierdrehen

Copying tools / Outils de decolletage

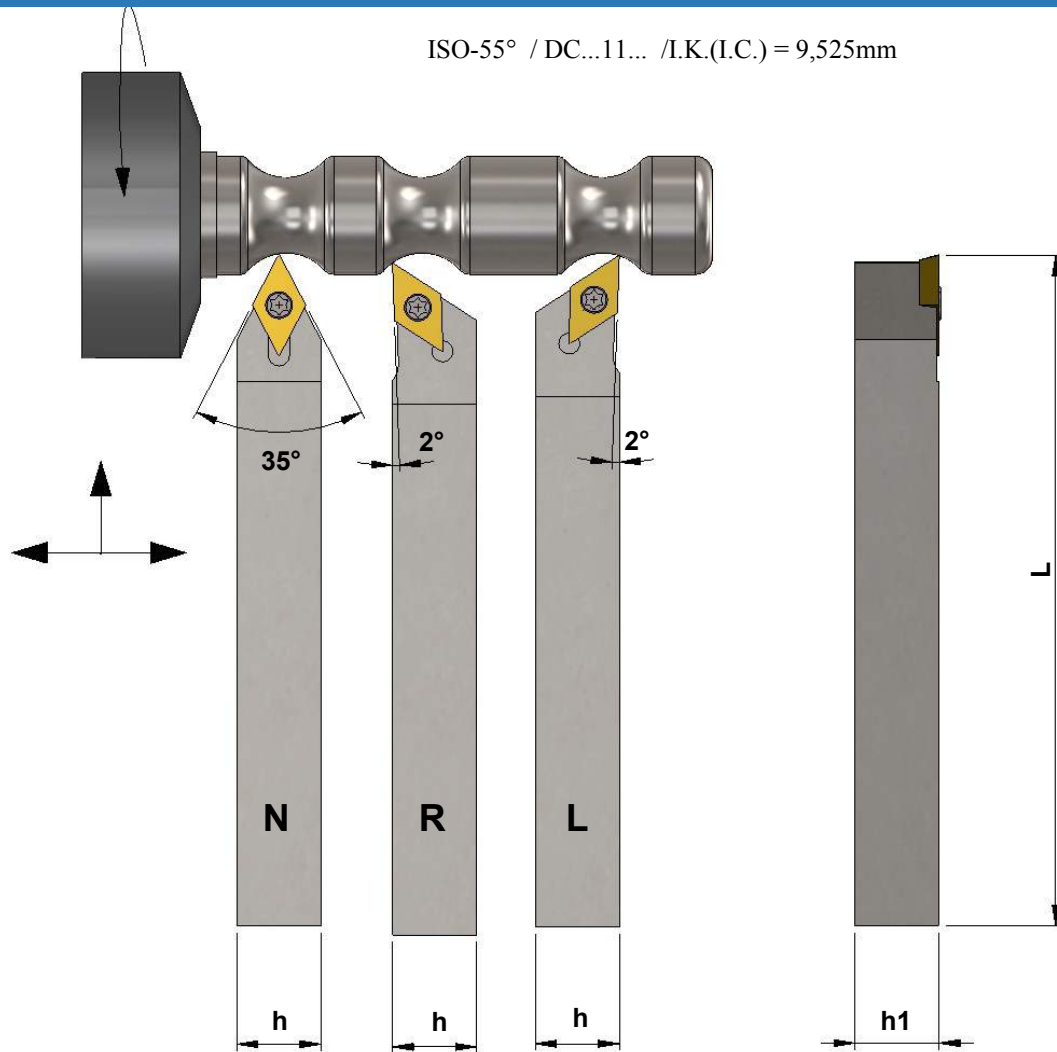

Bestellbezeichnung / Order number / No. de commande

Halter / Holder / Porte-outils	h	h1	L
SDAC-1155-1010-N	10	10	140
SDAC-1155-1212-L	12	12	140
SDAC-1155-1212-N	12	12	140
SDAC-1155-1212-R	12	12	140
SDAC-1155-1616-L	16	16	125
SDAC-1155-1616-N	16	16	125
SDAC-1155-1616-R	16	16	125
SDAC-1155-2020-L	20	20	125
SDAC-1155-2020-N	20	20	125
SDAC-1155-2020-R	20	20	125

Schlüssel/Key/Clef



Schraube/Screw/Vis



Kopierdrehen

Copying tools / Outils de decolletage

ISO-55° / DC...11... / I.K.(I.C.) = 9,525mm

Bestellbezeichnung / Order number / No. de commande

HM-Wendepplatten Carbide inserts Plaquettes réversibles	Unbeschichtet Uncoated Non-revêtu	r
DCMW-11T304-N-G6A	K10	0.4

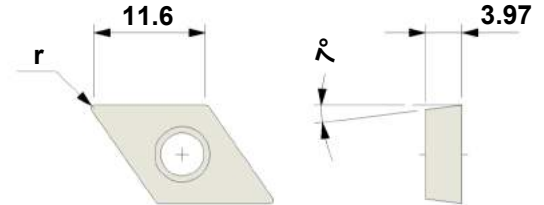

HM-Wendepplatten Carbide inserts Plaquettes réversibles	Unbeschichtet Uncoated Non-revêtu	r
DCGT-11T3005-N-ASF-G7B	K10	0.05
DCGT-11T302-N-ASF-G7B	K10	0.2

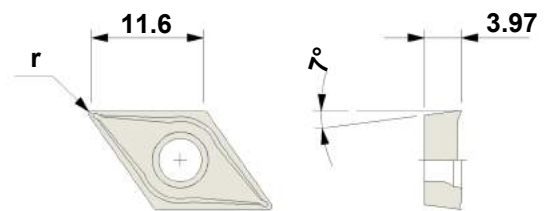

HM-Wendepplatten Carbide inserts Plaquettes réversibles	Unbeschichtet Uncoated Non-revêtu	r
DCGT-11T302-N-Alu-FA-G7B	K10	0.2
DCGT-11T304-N-Alu-FA-G7B	K10	0.4
DCGT-11T308-N-Alu-FA-G7B	K10	0.8

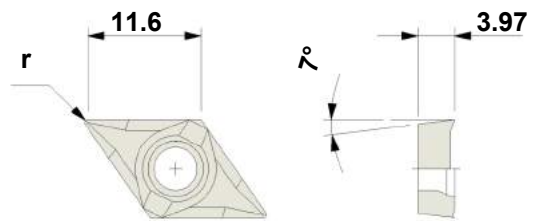

HM-Wendepplatten Carbide inserts Plaquettes réversibles	Unbeschichtet Uncoated Non-revêtu	r
DCGT-11T302-N-Alu-FB-G7B	K10	0.2
DCGT-11T304-N-Alu-FB-G7B	K10	0.4
DCGT-11T308-N-Alu-FB-G7B	K10	0.8

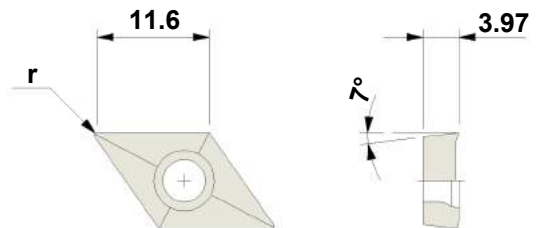

PKD-Schneidplatten PCD- inserts Plaquettes PCD	l	r	w
DCMW-11T302-FN-PKD	4.7	0.2	0°
DCMT-11T302-FN-PKD	4.7	0.2	7°
DCMT-11T304-FN-PKD	4.3	0.4	7°

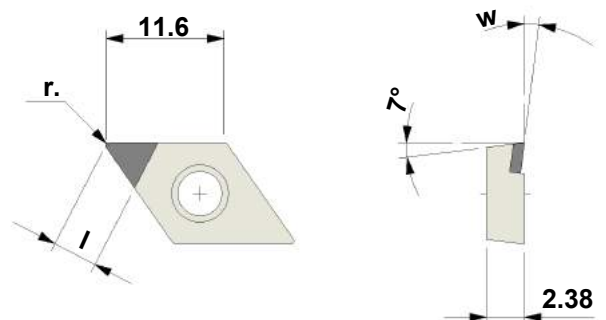

Langdrehen Long-turning / Chariotage

ISO-80° / CC...06... / I.K.(I.C.) = 6,35mm

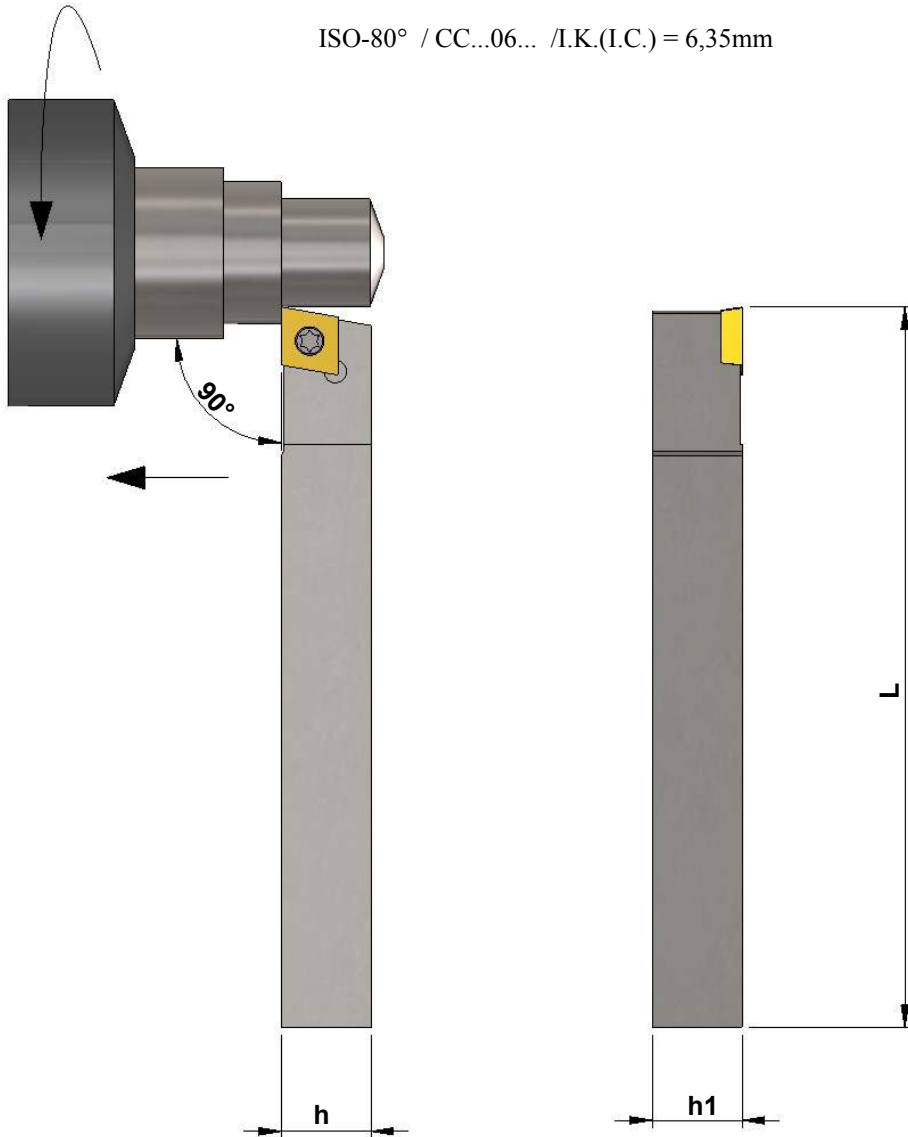

Rechtsausführung gezeichnet
Right-hand version shown
Exécution représentée à droite

Bestellbezeichnung / Order number / No. de commande

Halter / Holder / Porte-outils	h	h1	L
SLHC-06-0808-L/R	8	8	140
SLHC-06-1010-L/R	10	10	140
SLHC-06-1212-L/R	12	12	140
SLHC-06-1616-L/R	16	16	140

Schlüssel/Key/Clef



T7

Schraube/Screw/Vis



M2.5x7

Langdrehen Long-turning /Chariotage

ISO-80° / CC...06... /I.K.(I.C.) = 6,35mm

Bestellbezeichnung / Order number / No. de commande

HM-Wendepplatten Carbide inserts Plaquettes réversibles	Unbeschichtet Uncoated Non-revêtu	r
CCGT-060202-N-Alu-FA-G7B	K10	0.2
CCGT-060204-N-Alu-FA-G7B	K10	0.4

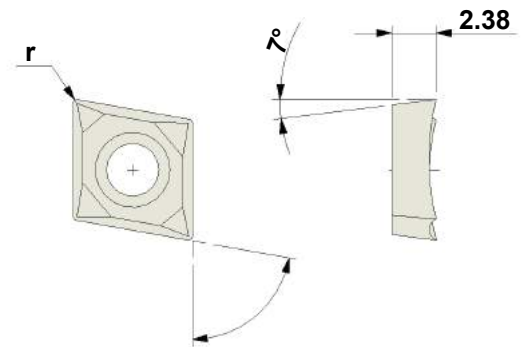

HM-Wendepplatten Carbide inserts Plaquettes réversibles	Unbeschichtet Uncoated Non-revêtu	r
CCGT-060202-N-Alu-FB-G7B	K10	0.2
CCGT-060204-N-Alu-FB-G7B	K10	0.4

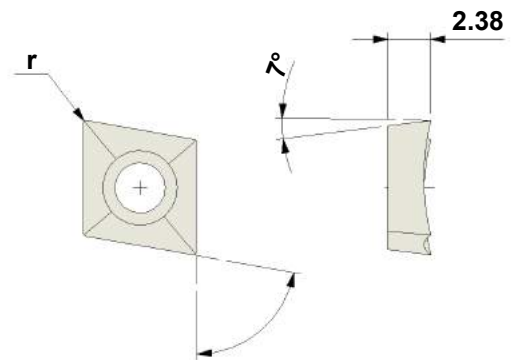

PKD-Schneidplatten PCD- inserts Plaquettes PCD	l	r	w
CCMT-060202-FN-PKD	3.4	0.2	7°
CCMT-060204-FN-PKD	3.2	0.4	7°

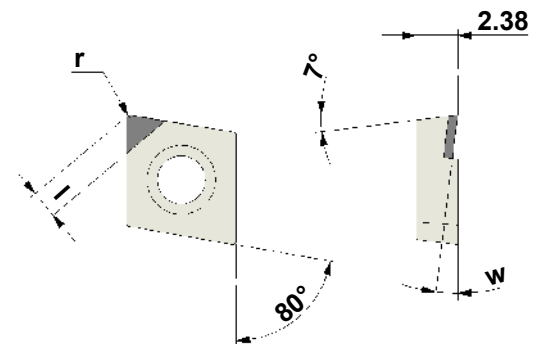



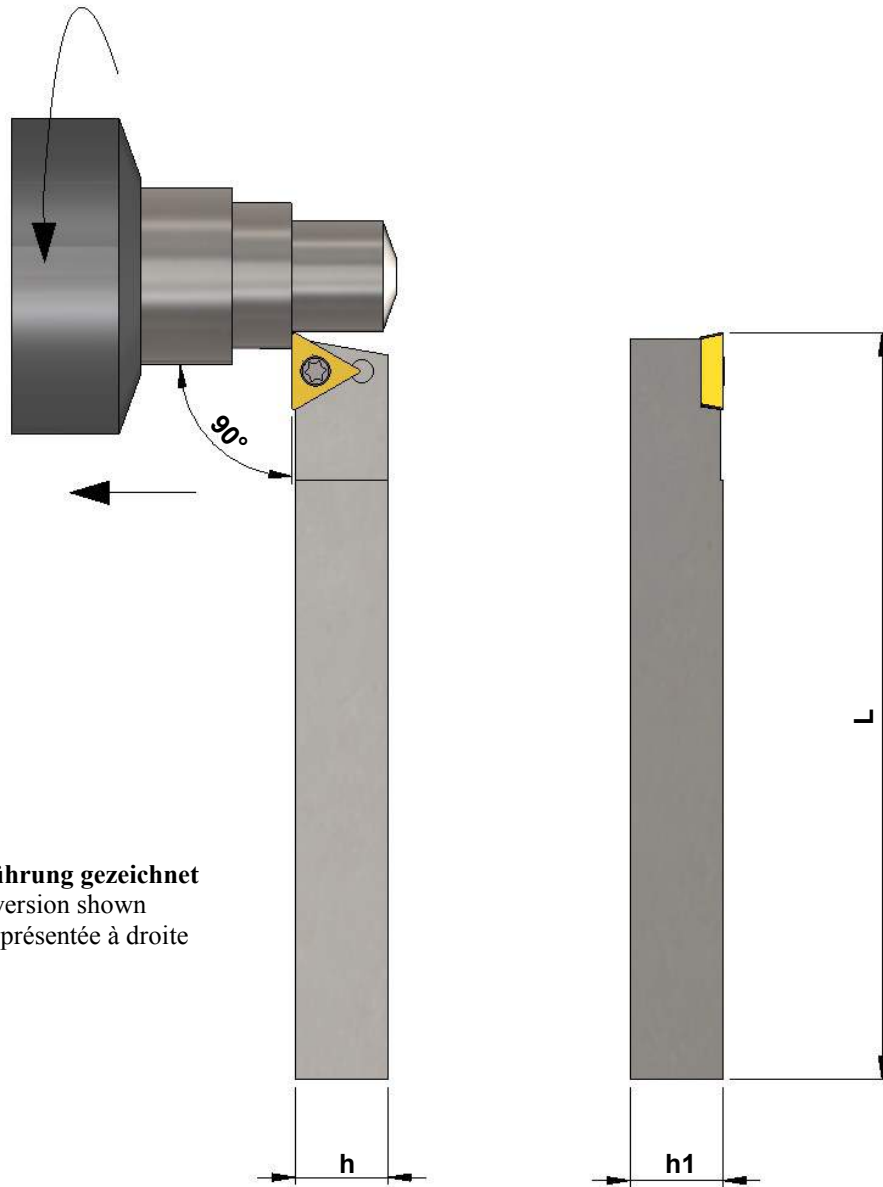



Langdrehen Long-turning /Chariotage



Rechtsausführung gezeichnet
Right-hand version shown
Exécution représentée à droite

Bestellbezeichnung / Order number / No. de commande

Halter / Holder / Porte-outils	h	h1	L	Für Wendeplatten for indexable inserts pour plaquettes réversibles
STAC-08-0808-L/R	8	8	140	TC...0802...
STAC-08-1010-L/R	10	10	140	TC...0802...
STAC-11-1010-L/R	10	10	140	TC...1102...
STAC-11-1212-L/R	12	12	140	TC...1102...
STAC-11-1616-L/R	16	16	125	TC...1102...
STAC-16-1616-L/R	16	16	125	TC...16T3...
STAC-16-2020-L/R	20	20	125	TC...16T3...

Schlüssel/Key/Clef  T6	Schraube/Screw/Vis  S203036
Schlüssel/Key/Clef  T7	Schraube/Screw/Vis  M2.5x7
Schlüssel/Key/Clef  T15	Schraube/Screw/Vis  M4x9.5

Langdrehen Long-turning /Chariotage

Bestellbezeichnung / Order number / No. de commande

HM-Wendeplatten Carbide inserts Plaquettes réversibles	Unbeschichtet Uncoated Non-revêtu	IK IC	s	r
TCGW-080202-N-G6A	K10	5.0	2.5	0.2
TCGW-110202-N-G6A	K10	6.35	2.5	0.2
TCGW-16T304-N-G6A	K10	9.525	3.97	0.4

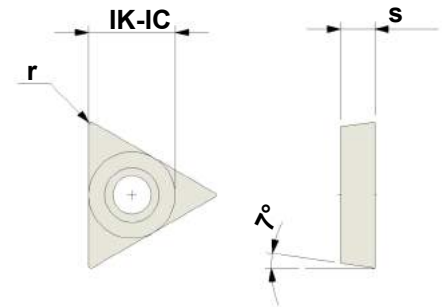

HM-Wendeplatten Carbide inserts Plaquettes réversibles	Unbeschichtet Uncoated Non-revêtu	IK IC	s	r
TCGT-110202-N-Alu-FA-G7B	K10	6.35	2.38	0.2
TCGT-110204-N-Alu-FA-G7B	K10	6.35	2.38	0.4
TCGT-16T302-N-Alu-FA-G7B	K10	9.525	3.97	0.2
TCGT-16T304-N-Alu-FA-G7B	K10	9.525	3.97	0.4
TCGT-16T308-N-Alu-FA-G7B	K10	9.525	3.97	0.8

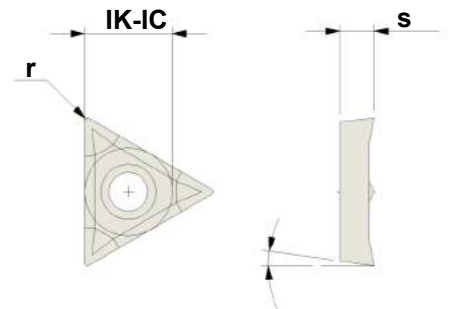

HM-Wendeplatten Carbide inserts Plaquettes réversibles	Unbeschichtet Uncoated Non-revêtu	IK IC	s	r
TCGT-110204-N-Alu-FB-G7B	K10	6.35	2.38	0.4
TCGT-16T304-N-Alu-FB-G7B	K10	9.525	3.97	0.4

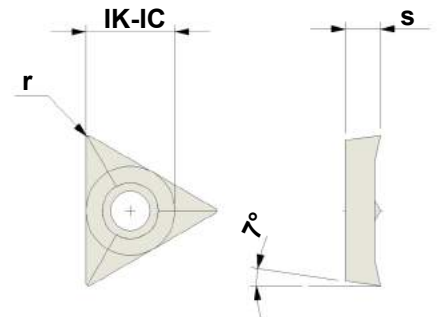

HM-Wendeplatten Carbide inserts Plaquettes réversibles	Unbeschichtet Uncoated Non-revêtu	IK IC	s	r
TCGT-080202-L/R-G1A	K10	5.0	2.5	0.2
TCGT-110201-L/R-G1A	K10	6.35	2.5	0.1
TCGT-110202-L/R-G1A	K10	6.35	2.5	0.2
TCGT-16T304-L/R-G1A	K10	9.525	3.97	0.4
TCGT-16T308-L/R-G1A	K10	9.525	3.97	0.8

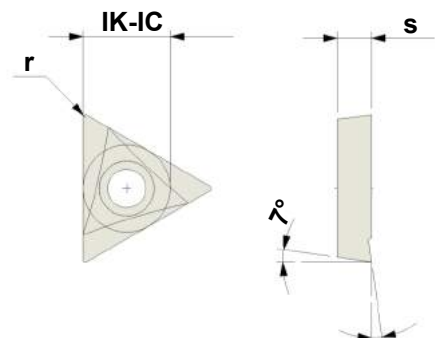





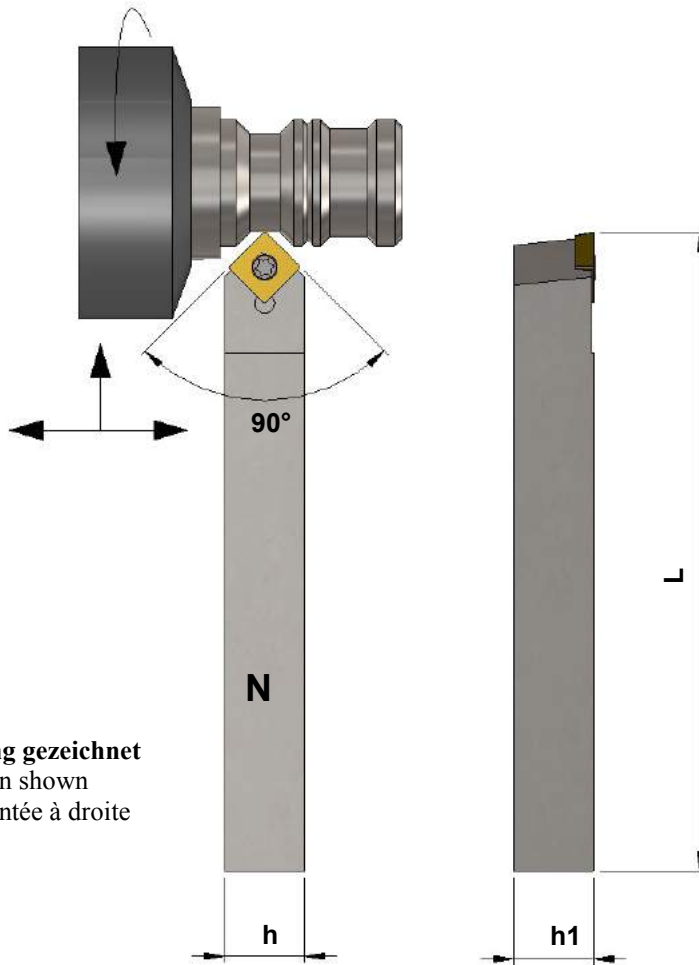





Kopierdrehen

Copying tools / Outils de decolletage



Rechtsausführung gezeichnet
 Right-hand version shown
 Exécution représentée à droite

Bestellbezeichnung / Order number / No. de commande

Halter / Holder / Porte-outils	h	h1	L	Für Wendepplatten for indexable inserts pour plaquettes réversibles	Schlüssel/Key/Clef	Schraube/Screw/Vis
SSAC-90-06-0808-N	8	8	140	SC...0602...	 T7	 S253545
SSAC-90-08-1010-N	10	10	140	SC...0830...	 T8	 S305550
SSAC-90-08-1212-N	12	12	140	SC...0830...		
SSAC-90-09-1212-N	12	12	140	SC...09T3...	 T15	 M4x9.5
SSAC-90-09-1616-N	16	16	125	SC...09T3...		
SSAC-90-10-1616-N	16	16	125	SC...1030...	 T8	 S305550
SSAC-90-10-2020-N	20	20	125	SC...1030...		
SSAC-90-12-1616-N	16	16	125	SC...1204...	 T20	 S509577
SSAC-90-12-2020-N	20	20	125	SC...1204...		

Kopierdrehen

Copying tools / Outils de decolletage

Bestellbezeichnung / Order number / No. de commande

HM-Wendeplatten Carbide inserts Plaquettes réversibles	Unbeschichtet Uncoated Non-revêtu	IK IC	s	r
SCGT-060202-N-G1A	K10	6.35	2.38	0.2
SCGT-083003-N-G1A	K10	8.0	3.0	0.3
SCGT-103003-N-G1A	K10	10.0	3.0	0.3

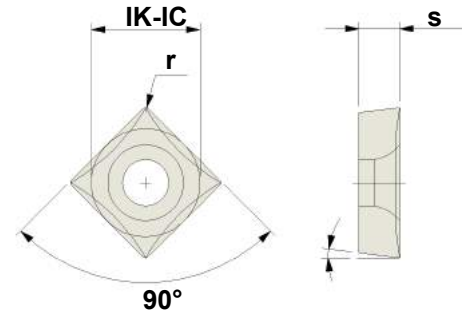

HM-Wendeplatten Carbide inserts Plaquettes réversibles	Unbeschichtet Uncoated Non-revêtu	IK IC	s	r
SCGT-09T304-N-Alu-FA-G7B	K10	9.525	3.97	0.4
SCGT-09T308-N-Alu-FA-G7B	K10	9.525	3.97	0.8

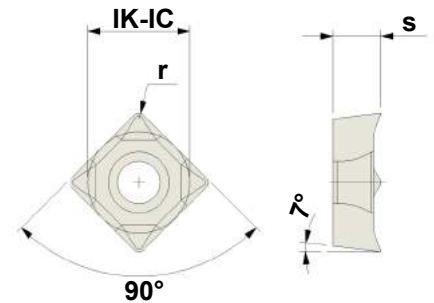

HM-Wendeplatten Carbide inserts Plaquettes réversibles	Unbeschichtet Uncoated Non-revêtu	IK IC	s	r
SCGT-120408-N-Alu-FA-G7B	K10	12.7	4.76	0.8
SCGT-120408-N-Alu-FB-G7B	K10	12.7	4.76	0.8

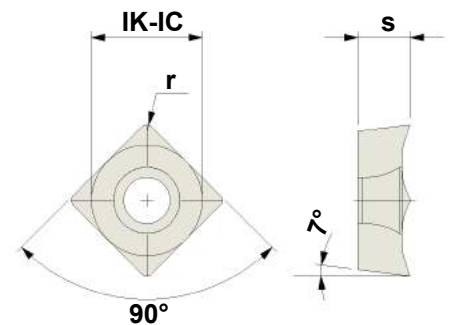

Außengewindestreihen

External threading / Filetage extérieur

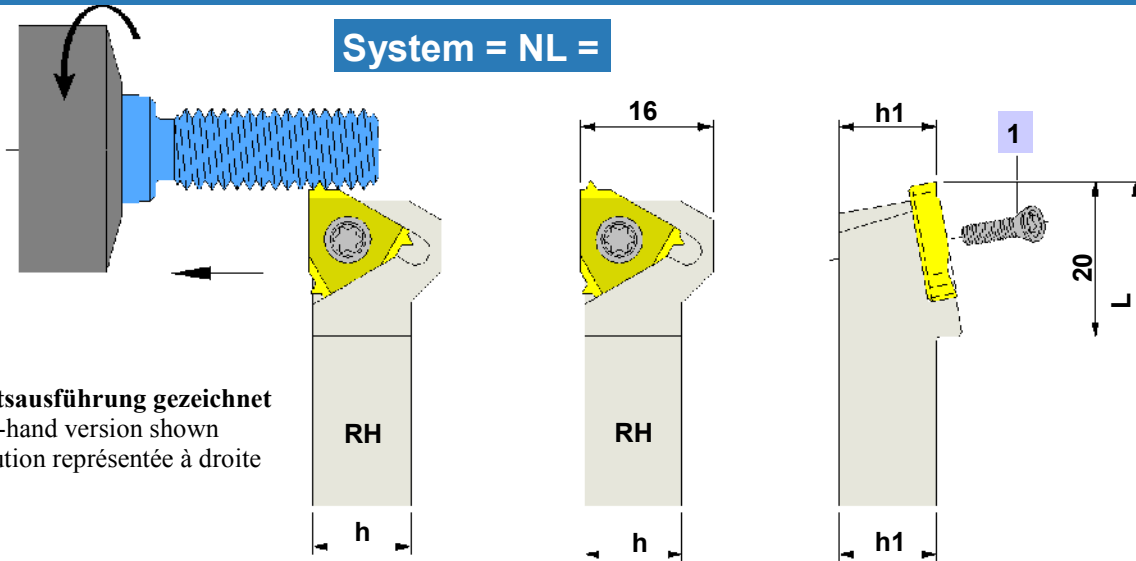

Rechtsausführung gezeichnet
Right-hand version shown
Exécution représentée à droite

Bestellbezeichnung / Order number / No. de commande

Halter / Holder / Porte-outils	h	h1	L	Halter / Holder / Porte-outils	h	h1	L
NL 10-3-120-RH	10	10	120	NL 10-3-120-LH	10	10	120
NL 12-3-105-RH	12	12	105	NL 12-3-105-LH	12	12	105

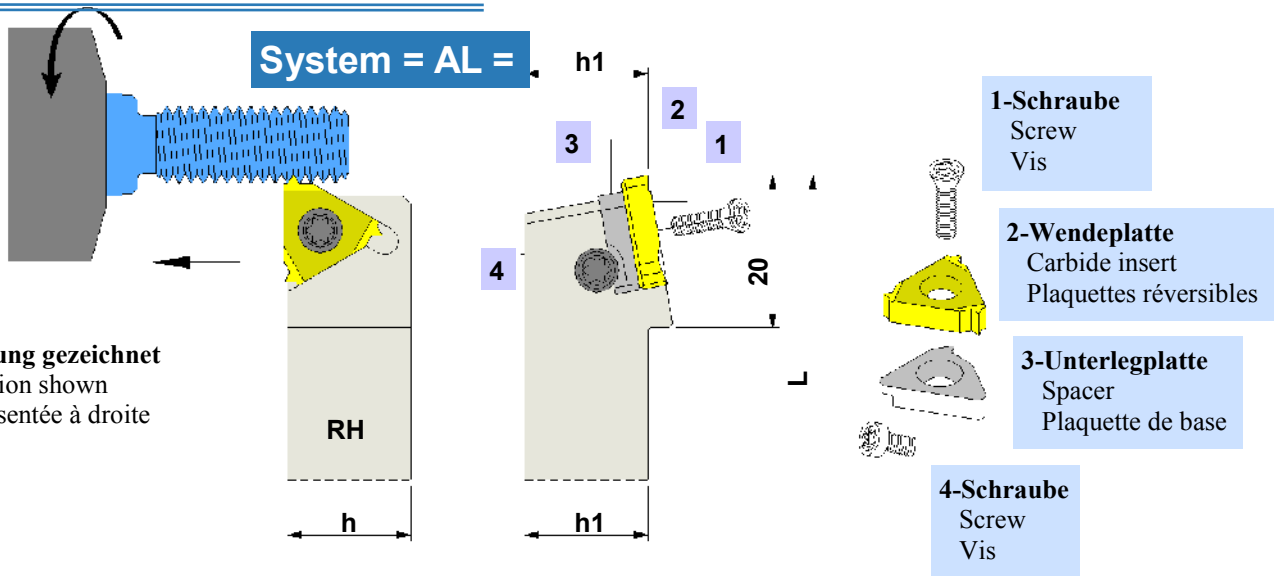

Rechtsausführung gezeichnet
Right-hand version shown
Exécution représentée à droite

Halter / Holder / Porte-outils	h	h1	L	1-Schraube Screw Vis	3-Unterlegplatte Spacer Plaque de base	4-Schraube Screw Vis	Schlüssel Key Clef
AL 16-3-100-RH	16	16	120	B6	YE3 	Sy3T	T10
AL 16-3-100-LH	16	16	100	B6	YI3 	Sy3T	T10

ISO-Metrisch 60°

ISO Metrisch 60° rechts ISO metric 60° right-hand ISO métrique 60° droite	ISO Metrisch 60° links ISO metric 60° left-hand ISO métrique 60° gauche	Steigung mm Pitch mm Pas en mm	X	Y
3 ER 0.35 ISO	3 EL 0.35 ISO	6.35	0.8	0.4
3 ER 0.4 ISO	3 EL 0.4 ISO	0.40	0.7	0.4
3 ER 0.45 ISO	3 EL 0.45 ISO	0.45	0.7	0.4
3 ER 0.5 ISO	3 EL 0.5 ISO	0.50	0.6	0.6
3 ER 0.6 ISO	3 EL 0.6 ISO	0.60	0.6	0.6
3 ER 0.7 ISO	3 EL 0.7 ISO	0.70	0.6	0.6
3 ER 0.75 ISO	3 EL 0.75 ISO	0.75	0.6	0.6
3 ER 0.8 ISO	3 EL 0.8 ISO	0.80	0.6	0.6
3 ER 1.0 ISO	3 EL 1.0 ISO	1.0	0.7	0.7
3 ER 1.25 ISO	3 EL 1.25 ISO	1.25	0.8	0.8
3 ER 1.5 ISO	3 EL 1.5 ISO	1.5	0.8	1.0
3 ER 1.75 ISO	3 EL 1.75 ISO	1.75	0.9	1.2
3 ER 2.0 ISO	3 EL 2.0 ISO	2.0	1.0	1.3
3 ER 2.5 ISO	3 EL 2.5 ISO	2.5	1.1	1.5
3 ER 3.0 ISO	3 EL 3.0 ISO	3.0	1.2	1.6

BSW-Whitworth 55°

ISO Metrisch 60° rechts ISO metric 60° right-hand ISO métrique 60° droite	ISO Metrisch 60° links ISO metric 60° left-hand ISO métrique 60° gauche	Stg.-Gänge/Inch Pitch -threads/inch Filets -pouce/inch	X	Y
3 ER 72 W	3 EL 72 W	72	0.7	0.4
3 ER 60 W	3 EL 60 W	60	0.7	0.4
3 ER 56 W	3 EL 56 W	56	0.7	0.4
3 ER 48 W	3 EL 48 W	48	0.6	0.6
3 ER 40 W	3 EL 40 W	40	0.6	0.6
3 ER 36 W	3 EL 36 W	36	0.6	0.6
3 ER 32 W	3 EL 32 W	32	0.6	0.6
3 ER 28 W	3 EL 28 W	28	0.6	0.7
3 ER 26 W	3 EL 26 W	26	0.7	0.8
3 ER 24 W	3 EL 24 W	24	0.7	0.8
3 ER 22 W	3 EL 22 W	22	0.8	0.9
3 ER 20 W	3 EL 20 W	20	0.8	0.9
3 ER 19 W	3 EL 19 W	19	0.8	1.0
3 ER 18 W	3 EL 18 W	18	0.8	1.0
3 ER 16 W	3 EL 16 W	16	0.9	1.1
3 ER 14 W	3 EL 14 W	14	1.0	1.2
3 ER 12 W	3 EL 12 W	12	1.1	1.4
3 ER 11 W	3 EL 11 W	11	1.1	1.5
3 ER 10 W	3 EL 10 W	10	1.1	1.5
3 ER 9 W	3 EL 9 W	9	1.2	1.7
3 ER 8 W	3 EL 8 W	8	1.2	1.5

UN-American Unified 60°

ISO Metrisch 60° rechts ISO metric 60° right-hand ISO métrique 60° droite	ISO Metrisch 60° links ISO metric 60° left-hand ISO métrique 60° gauche	Stg.-Gänge/Inch Pitch -threads/inch Filets -pouce/inch	X	Y
3 ER 72 UN	3 EL 72 UN	72	0.8	0.4
3 ER 64 UN	3 EL 64 UN	64	0.8	0.4
3 ER 56 UN	3 EL 56 UN	56	0.7	0.4
3 ER 48 UN	3 EL 48 UN	48	0.6	0.6
3 ER 44 UN	3 EL 44 UN	44	0.6	0.6
3 ER 40 UN	3 EL 40 UN	40	0.6	0.6
3 ER 36 UN	3 EL 36 UN	36	0.6	0.6
3 ER 32 UN	3 EL 32 UN	32	0.6	0.6
3 ER 28 UN	3 EL 28 UN	28	0.6	0.7
3 ER 27 UN	3 EL 27 UN	27	0.7	0.8
3 ER 24 UN	3 EL 24 UN	24	0.7	0.8
3 ER 20 UN	3 EL 20 UN	20	0.8	0.9
3 ER 18 UN	3 EL 18 UN	18	0.8	1.0
3 ER 16 UN	3 EL 16 UN	16	0.9	1.1
3 ER 14 UN	3 EL 14 UN	14	1.0	1.2
3 ER 13 UN	3 EL 13 UN	13	1.0	1.3
3 ER 12 UN	3 EL 12 UN	12	1.1	1.4
3 ER 11.5 UN	3 EL 11.5 UN	11.5	1.1	1.5
3 ER 11 UN	3 EL 11 UN	11	1.1	1.5
3 ER 10 UN	3 EL 10 UN	10	1.1	1.5
3 ER 9 UN	3 EL 9 UN	9	1.2	1.7
3 ER 8 UN	3 EL 8 UN	8	1.2	1.6

Rechter Halter rechte Platte
Right-hand holder right-hand insert
Porte-outil droite Plaquette droite

Linker Halter linke Platte
Left-hand holder left-hand insert
Porte-outil gauche Plaquette gauche

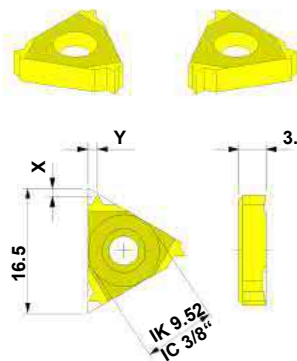

Rechtsausführung gezeichnet
Right-hand version shown
Exécution représentée à droite

Vollprofil
Solid profile
Profil intégral

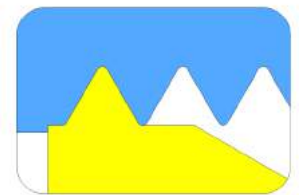

Unbeschichtet
Uncoated
Non-revêtu

K20

ISO M/UN 60° rechts ISO M/UN 60° right-hand ISO M/UN 60° droite	ISO M/UN 60° links ISO M/UN 60° left-hand ISO M/UN 60° gauche	Steigung mm Pitch mm Pas en mm	Stg.-Gänge/Inch Pitch -threads/inch Filets -pouce/inch	X	Y
3 ER A 60	3 EL A 60	0.5-1.5	48-16	0.8	0.9
3 ER G 60	3 EL G 60	1.75-3.0	14-8	1.2	1.7
3 ER AG 60	3 EL AG 60	0.5-3.0	48-8	1.2	1.7

ISO-Metrisch 60° UN-American Unified 60°



Teilprofil
Partial profile
Profil partiel

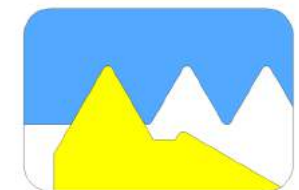

BSW-55° rechts BSW-55° right-hand BSW-55° droite	BSW-55° links BSW-55° left-hand BSW-55° gauche	Steigung mm Pitch mm Pas en mm	Stg.-Gänge/Inch Pitch -threads/inch Filets -pouce/inch	X	Y
3 ER A 55	3 EL A 55	0.5-1.5	48-16	0.8	0.9
3 ER G 55	3 EL G 55	1.75-3.0	14-8	1.2	1.7
3 ER AG 55	3 EL AG 55	0.5-3.0	48-8	1.2	1.7

BSW-Witworth 55°

Unbeschichtet
Uncoated
Non-revêtu

K20



Technische Angaben

Technical Details / Données techniques

Hartmetallsorten - Anwendungsempfehlung

Carbide grades - Recommended for:
Nuances des carbure -Recommandé pour:

K10

Für Automatenstähle und Buntmetalle, (Kupfer, Messing, Aluminium) zum Drehen kleinster bis mittlerer Spanquerschnitte von 70-170 m/min. Schnittgeschwindigkeit.

For free cutting steel and non-ferrous metals (copper, brass, aluminium), for turning from small to medium chip sections at a cutting speed of 70-170 m/min.

Pour aciers de décolletage et métaux non-ferreux (cuivre, laiton, aluminium), pour le tournage de sections de copeaux petits à moyens, à une vitesse de coupe de 70-170 m/min.

UFK-2

Für Automatenstähle und Buntmetalle, (Kupfer, Messing, Aluminium) zum Drehen kleinster bis mittlerer Spanquerschnitte von 70-170 m/min. Schnittgeschwindigkeit.

For free cutting steel and non-ferrous metals (copper, brass, aluminium), for turning from small to medium chip sections at a cutting speed of 70-170 m/min.

Pour aciers de décolletage et métaux non-ferreux (cuivre, laiton, aluminium), pour le tournage de sections de copeaux petits à moyens, à une vitesse de coupe de 70-170 m/min.

PKD - Anwendungsempfehlung

PCD - Recommended for:
PCD - Recommandé pour:

PKD PC

PKD-Polykristalliner Diamant eignet sich zur Bearbeitung von Nichteisenmetallen wie z.B Aluminium, Kupfer und deren Legierungen, Messing und Bronze aber auch Kunststoffe, Holz sowie Keramik, Edel- und Hartmetalle. Die Schneide bleibt auch bei schwierigsten Bearbeitungen scharf, bei Schnittgeschwindigkeiten bis zu 2000 m/min.

PCD-Polycrystalline diamond is suitable for machining non-ferrous metals such as aluminium, copper and their alloys, brass and bronze, but also plastics, wood and ceramics, noble metals and carbide. The cutting edge remains sharp even in difficult machining conditions, with speeds of up to 2000 m/min.

PCD-Diamant polycristallin convient pour l'usinages des non-ferreux, par exemple aluminium, cuivre et les alliages, laiton et bronze, également pour plastique, bois, céramique, métal aux précieux et carbure. Le tranchant reste aiguisé aussi sous conditions difficiles, à une vitesse de coupe jusqu'à 2000 m/min.



Technische Angaben

Technical Details / Données techniques

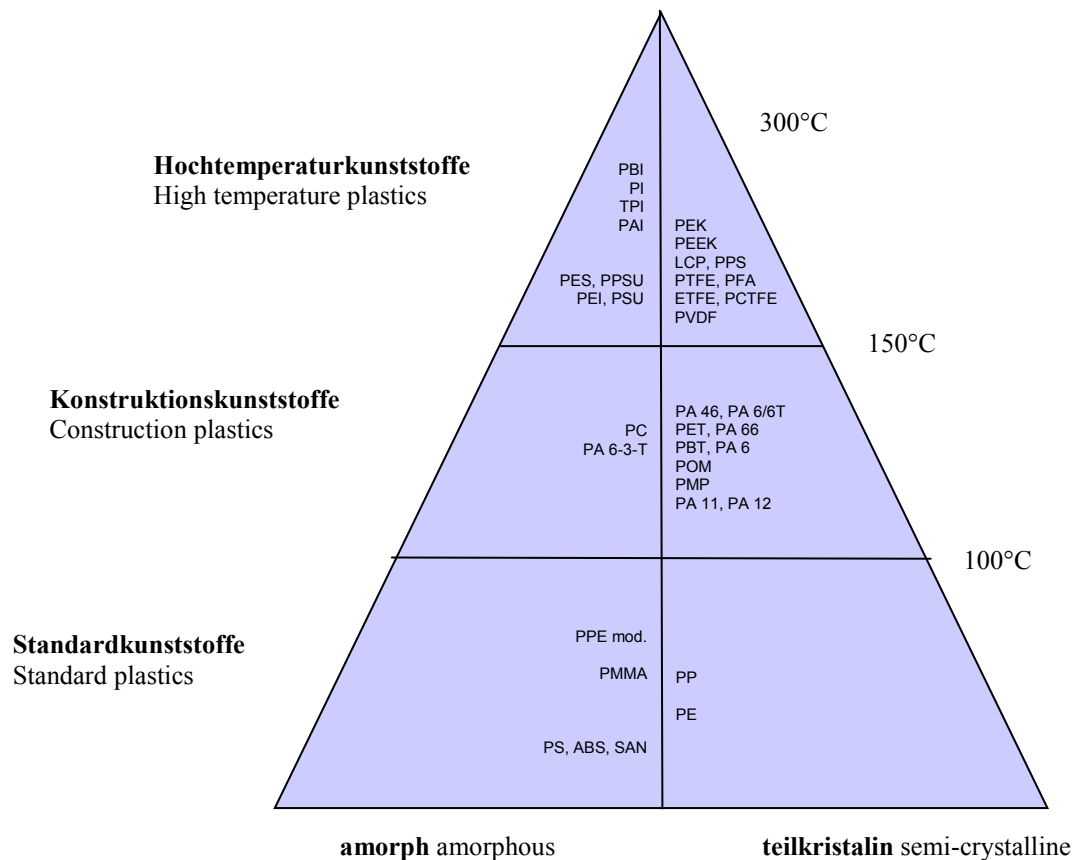

Beschichtung -Anwendungsempfehlung

Coating -Recommended for:
Revêtement - Recommandé pour:

BDD

Multilayer Diamantbeschichtung zur spanenden Bearbeitung von faserverstärkten Kunststoffen sowie Verbund-und Sandwichmaterialien (Al-Ti) und Ti-CFK

Multilayer diamond coating for machining fiber reinforced plastics as well as composite-and sandwich materials (Al-Ti) and Ti-CFC

Multilayer diamante revêtement pour traitement de renforcé de fibre ainsi composite-et sandwich matériaux (Al-Ti) et Ti-CFC



Technische Angaben

Technical Details / Données techniques

Spanleitstufengeometrie - Anwendungsempfehlung

Chip breaker geometry - Recommended for:
Géométrie de guide-copeaux -Recommandé pour:

G1 A

→ **Geometrie mit geschliffener Spanleitstufe, ausschließlich für die Feinbearbeitung entwickelt.**
Geometry with ground chip breaker, designed exclusively for fine machining.
Géométrie avec un guide-copeaux rectifié, une conception particulière pour le façonnement fin.

↳ **Allseits geschliffene Ausführung**
All sides ground
Exécution toutes faces rectifiées

Schneidkante scharf
Sharp cutting edge
Tranchant à arête vive

G6 A

→ **Ohne Spanleitstufe für Fein- bis mittlere Bearbeitung von kurzspanenden Werkstoffen.**
Without chip breaker for fine machining and medium machining of short chipping materials.
Sans guide-copeaux pour la finition et la semi-finition dans les matériaux à copeaux fragmentés.

↳ **Allseits geschliffene Ausführung**
All sides ground
Exécution toutes faces rectifiées

Schneidkante scharf
Sharp cutting edge
Tranchant à arête vive

G7 B

→ **Großer positiver Spanwinkel, für Drehen von Aluminium und NE-legierten Werkstoffen.**
Big positive rake angle, for turning aluminium and non-ferrous materials.
Angle de coupe positif important, pour tournage de l'aluminium et des non-ferreux.

↳ **Umfang geschliffen Spanleitstufe gesintert**
Circumference ground, chip breaker sintered
Circonférence rectifiée guide-copeaux fritté

Schneidkante scharf
Sharp cutting edge
Tranchant à arête vive



Minifix Innenbearbeitungssysteme System for Internal-Machining

Viele Sonderlösungen bietet das System „Minifix“ für die Innenbearbeitung

This system offers many off-standard solutions for internal machining



Stufenbohrwerkzeuge Stepdrill tools

Hervorragende Oberflächen durch Feinstschleiftechnik
Bohren und Gewindeschneiden in einem Arbeitsgang als Sonderwerkzeug

Excellent surface quality due to a fine grinding technology
Boring and Threading in one operation with a special tool



Spezial Fräswerkzeuge Special milling tools

Wir bieten Sonderbeschichtungen für Trockenbearbeitung

We offer special coatings for dry processing



Wendepplattenwerkzeuge Insert tools

In erster Linie werden allseitig geschliffene Wendepplatten eingesetzt.
Sie gewähren eine hohe Umschlag- und Drehgenauigkeit

We specialize mostly in ground high-quality carbide inserts for fine turning operations, with highest changing precision

**Bitte fordern Sie unsere Kataloge an !
Please order our catalogs!**



- Rotowibex -
Aussengewinde-Wirbelwerkzeuge
 External threading tools

Eine spezielle HM-Sorte der Wechselschneiden garantiert hervorragende Standzeiten

A special carbide grade guarantees outstanding tool lifes

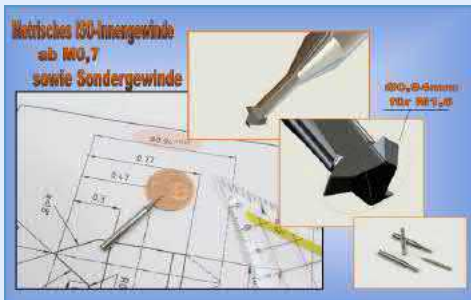

Miniwibex
Innengewinde-Wirbelwerkzeuge
 Internal threading tools

Rationelle Fertigung durch mehrgängige Werkzeuge

Efficient production due to multiple thread tools



SSXA
Drehsystem
 Turning System

Das bewährte und vielseitige Werkzeug- und Wendeplattensystem für Langdrehautomaten

An approved and versatile system with indexable inserts for sliding head machines



SSXAC
Drehsystem
 Turning System

Ein System-Viele Möglichkeiten

One toolholder-many applications

Bitte fordern Sie unsere Kataloge an !
Please order our catalogs!

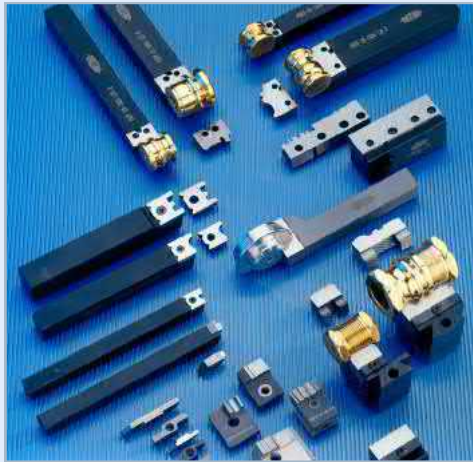

Profilgeschliffene Werkzeugsysteme Profile Ground Tooling Systems

Die von uns verwendeten Werkstoffe und Hartmetalle sind von einer ausgesuchten und bewährten Qualität.

All materials used are of exceptional, well-established quality



Profilstempel Profile Dies

Mit neuen Schleifverfahren können wir viele Arten von Profilstempel anfertigen, selbst von Ihnen hergestellte DXF-Formate können in unsere Konstruktionsprogramme übernommen werden.

With a new grinding method we can produce various profile form dies. Your dxf-files can be read into our construction programmes.



Zubehörwerkzeuge für Drehautomaten Accessory tools for automatic lathes

**Bitte fordern Sie unsere Kataloge an !
Please order our catalogs!**

Otto Dieterle Spezialwerkzeuge GmbH

Predigerstr. 56
78628 Rottweil, Germany

Tel.: +49 (0) 741 / 9 42 05 - 0
Fax: +49 (0) 741 / 9 42 05 - 50
Email: info@dieterle-tools.com

www.dieterle-tools.com

