

MFE-1K

(6, 8, 10 mm Ø)



+7 812 335 59 35
info@sunttools.ru



www.dieterle-tools.com



System MFE-IK

Innenbearbeitung mit Kühlmittelzufuhr

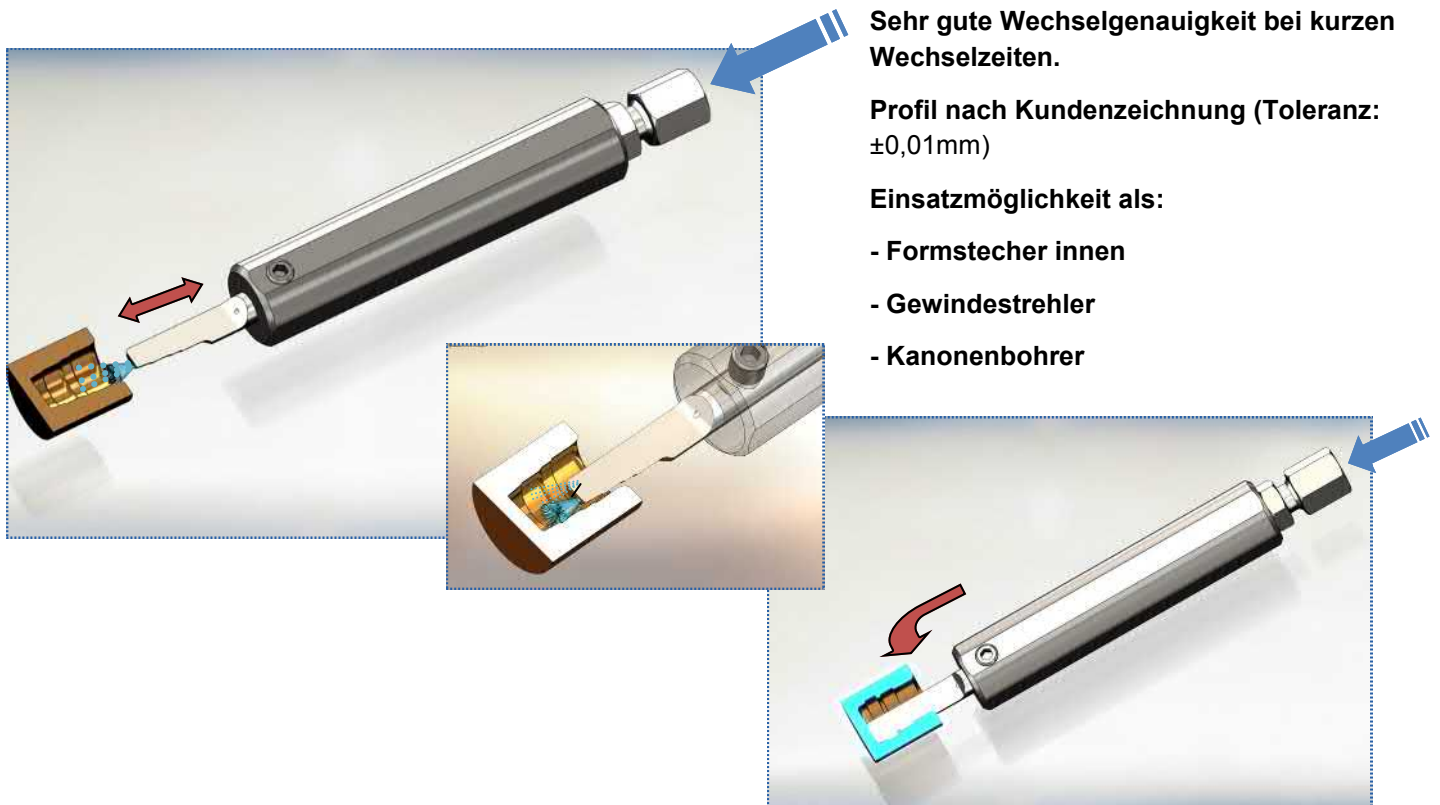
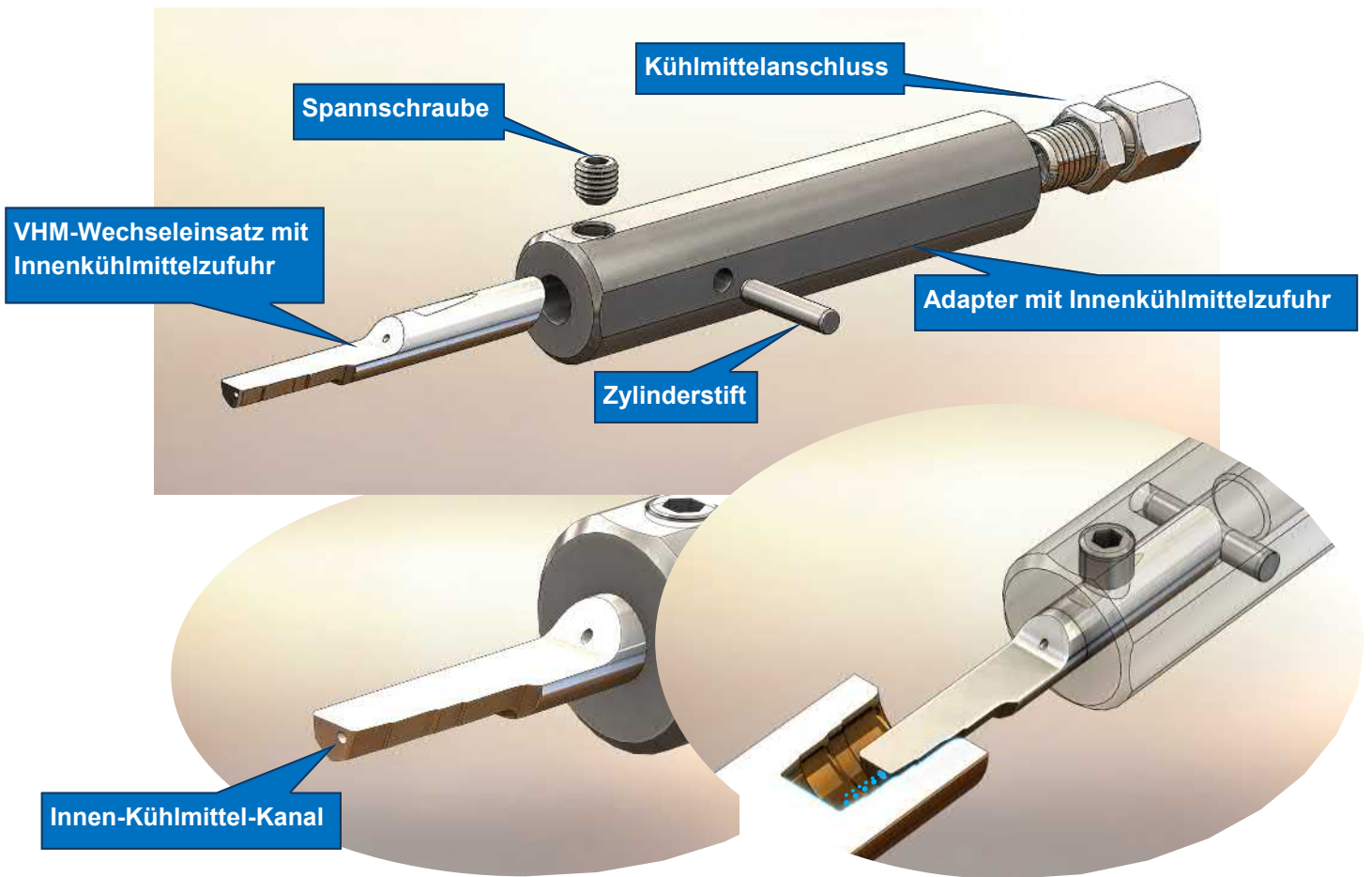

System MFE-IK

Innenbearbeitung mit Kühlmittelzufuhr

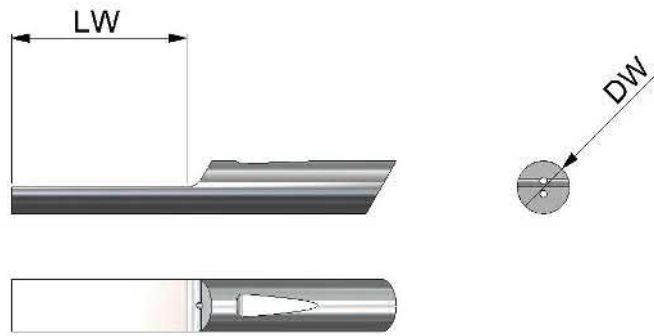

VHM-Wechseleinsatz

Artikel Nr.	Bezeichnung	DW	LW	HM-Sorte
144396	MFE-IK-06-20-HM	6	20	K40UF
144395	MFE-IK-08-25-HM	8	25	K40UF
144392	MFE-IK-10-30-HM	10	30	K40UF

Zubehör

Bezeichnung

Gewindestift	M5x5-N-ISO 4029
Zylinderstift	Ø3x14-A-St. ISO 8734
IK-Anschluß	GE-04LLM-CF M8x1

Zylinderstift

IK-Anschluss

Gewindestift

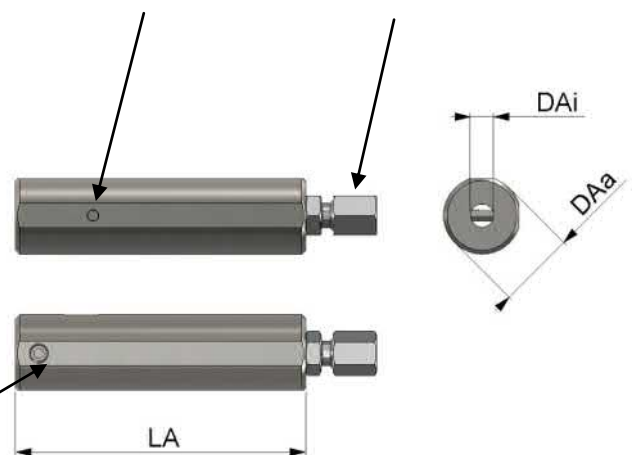

Adapter mit IK

Artikel Nr.	Bezeichnung	DAi	DAa	LA
144390	MFE-IK-06-20-A-16	6	16	75
144388	MFE-IK-06-20-A-20	6	20	75
144386	MFE-IK-08-25-A-16	8	16	75
144385	MFE-IK-08-25-A-20	8	20	75
144383	MFE-IK-10-30-A-16	10	16	75
144381	MFE-IK-10-30-A-20	10	20	75

Otto Dieterle Spezialwerkzeuge GmbH

Predigerstr. 56
78628 Rottweil, Germany

Tel.: +49 (0) 741 / 9 42 05 - 0
Fax: +49 (0) 741 / 9 42 05 - 50
Email: info@dieterle-tools.com

www.dieterle-tools.com

